

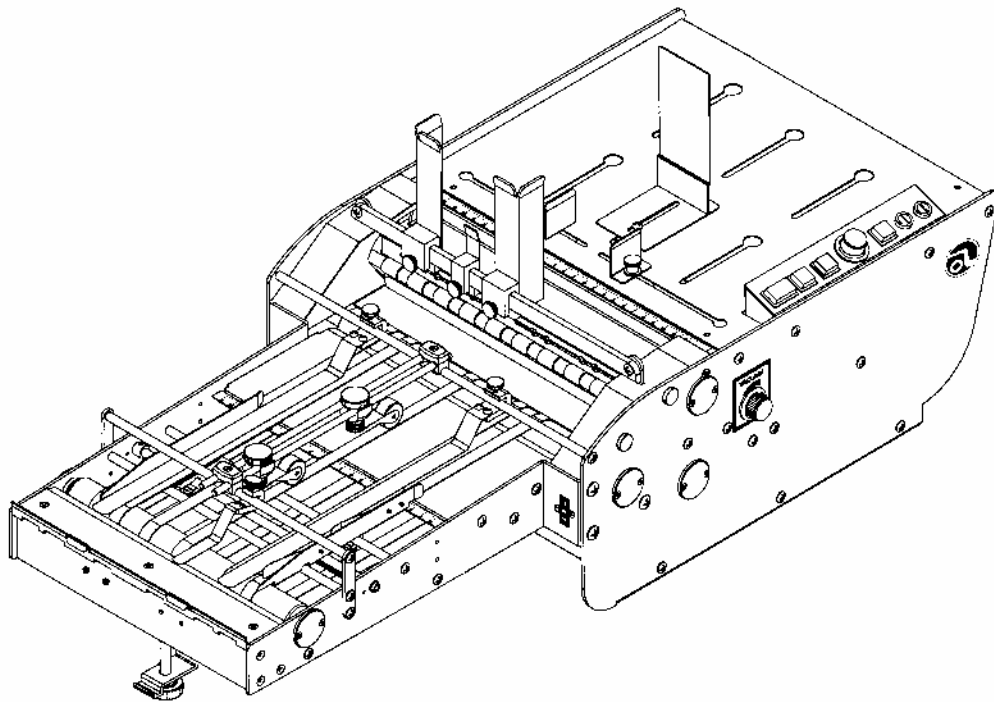

ASTRO

AMC-2000 SERIES ENVELOPE FEEDER



PARTS CATALOG

GROUP 1

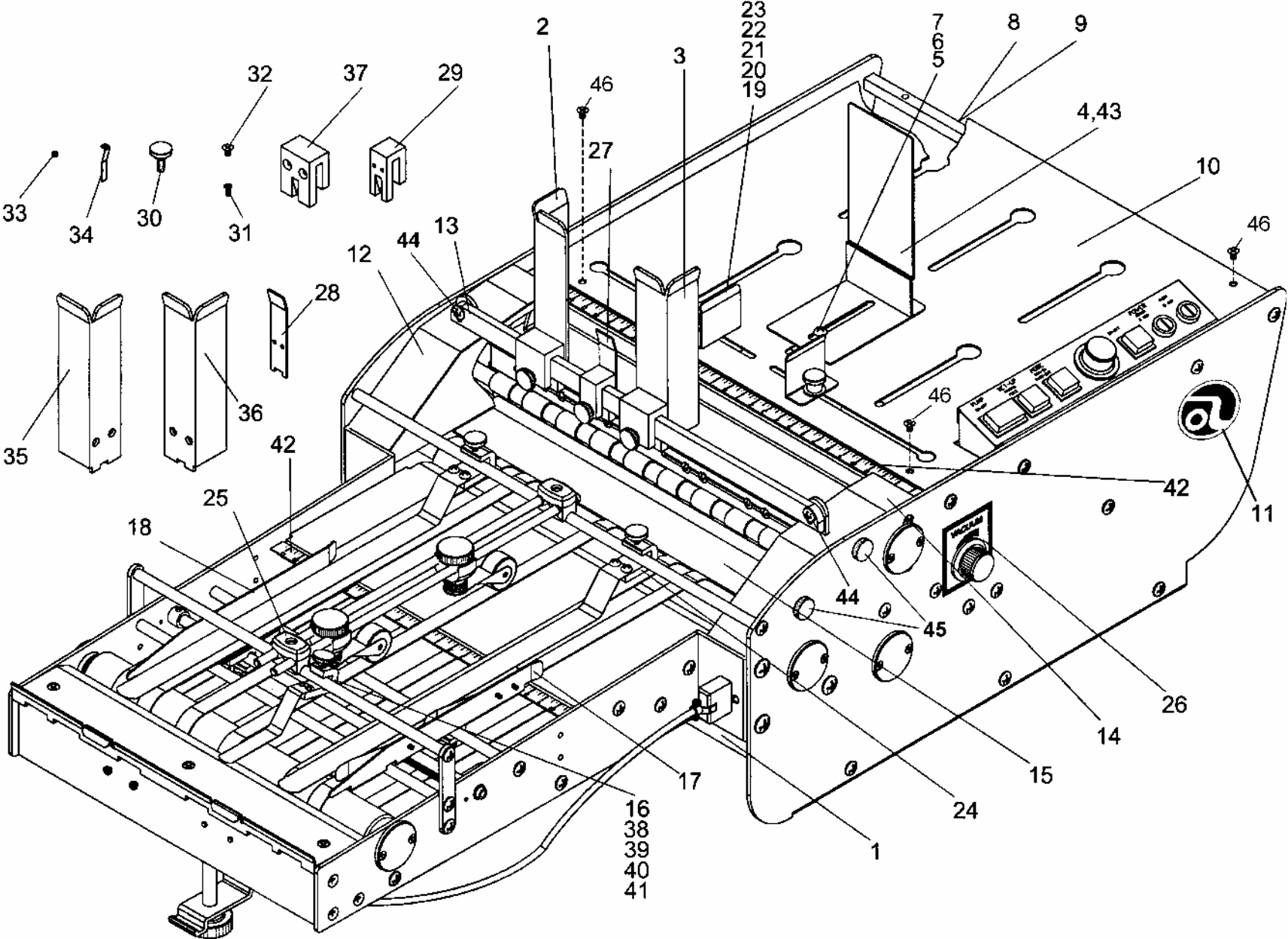

KEY #	PART #	DESCRIPTION	QTY.	KEY #	PART #	DESCRIPTION	QTY.
1.	84-100-56B	FRONT FRAME CLOSURE	1	24.	84-125-108	RETAINER STRAP ASSEMBLY	2
2.	71-140-08	FRONT R/H ENV. GUIDE ASSY	1	25.	84-130-20	SKID WHEEL ASSEMBLY	1
*2.	71-140-08L	FRONT R/H ENV. GUIDE ASSY. (LONG)		26.	123-0407	VACUUM DECAL	1
3.	71-140-10	FRONT L/H ENV. GUIDE ASSEMBLY	1	27.	71-140-13	CENTER GUIDE ASSEMBLY	1
*3.	71-140-10L	FRONT L/H ENV. GUIDE ASSY. (LONG)		28.	71-108-15	PLATE, CENTER GUIDE	1
4.	84-108-25	REAR ENVELOPE GUIDE	1	29.	71-109-11	CLAMP CENTER GUIDE	1
5.	84-108-22	SCREW, 1/4-20, REAR ENV. GUIDE	1	30.	71-108-09	THUMBSCREW	3
6.	84-108-23	T-NUT, REAR ENV. GUIDE	1	31.	123-0975	SCREW, 4-40 X 1/4 PHL. FL. HD.	2
7.	123-0073	PIN, COTTER 1/16 X 3/4	1	32.	123-0126	SCREW, 8-32 X 1/4	4
8.	84-108-02	BEAM, REAR TOP PLATFORM	1	33.	123-0010	SET SCREW, 6-32	3
9.	84-100-22B	REAR FRAME CLOSURE	1	34.	71-109-05	SHEET SEPARATOR (STANDARD)	3
10.	84-108-03	TOP PLATFORM	1	34.	71-109-05B	SHEET SEPARATOR (HEAVY)	3
11.	123-0752	ASTRO LOGO DECAL	1	35.	71-108-06A	ENVELOPE GUIDE, R/H FRONT	1
12.	84-100-75B	COVER, R/H	1	36.	71-108-04A	ENVELOPE GUIDE, L/H FRONT	1
13.	84-100-81	BEAM, FRONT SUPPORT	1	37.	71-109-03A	CLAMP, ENVELOPE GUIDE	2
14.	84-100-74B	COVER, L/H	1	38.	84-125-111	RETAINER STRAP, FRONT	1
15.	84-100-20	PLATE, FEEDER FRONT	1	39.	84-125-112	CLAMP, FRONT RETAINER	1
16.	84-125-110	FRONT RETAINER STRAP ASSEMBLY	1	40.	71-109-07	THUMBSCREW	1
17.	56-114-04	SIDE GUIDE ASSEMBLY, L/H	1	41.	123-0127	SCREW, 6-32 X 1/8	2
18.	56-114-03	SIDE GUIDE ASSEMBLY, R/H	1	42.	123-0328	SCALE GUIDE	2
19.	84-100-15	GUIDE ASSEMBLY, ANTI-SKEWING	2	43.	84-108-20	REAR ENVELOPE GUIDE ASSEMBLY	1
20.	123-0433	BOLT, CARRIAGE	2	*43.	84-108-20L	REAR ENVELOPE GUIDE ASSY (LONG)	
21.	123-0462	WASHER	2	44.	123-0180	SCREW, 10-32 X 1/2 TRUSS. H. PH.	2
22.	123-0460	KNOB	2	45.	84-114-34	THUMBSCREW ASSEMBLY	4
23.	74-100-13	GUIDE PLATE	2	46.	123-0017	SCREW, 10-32 X 1/4	4

* NOT SHOWN

GROUP 1

GROUP 1A

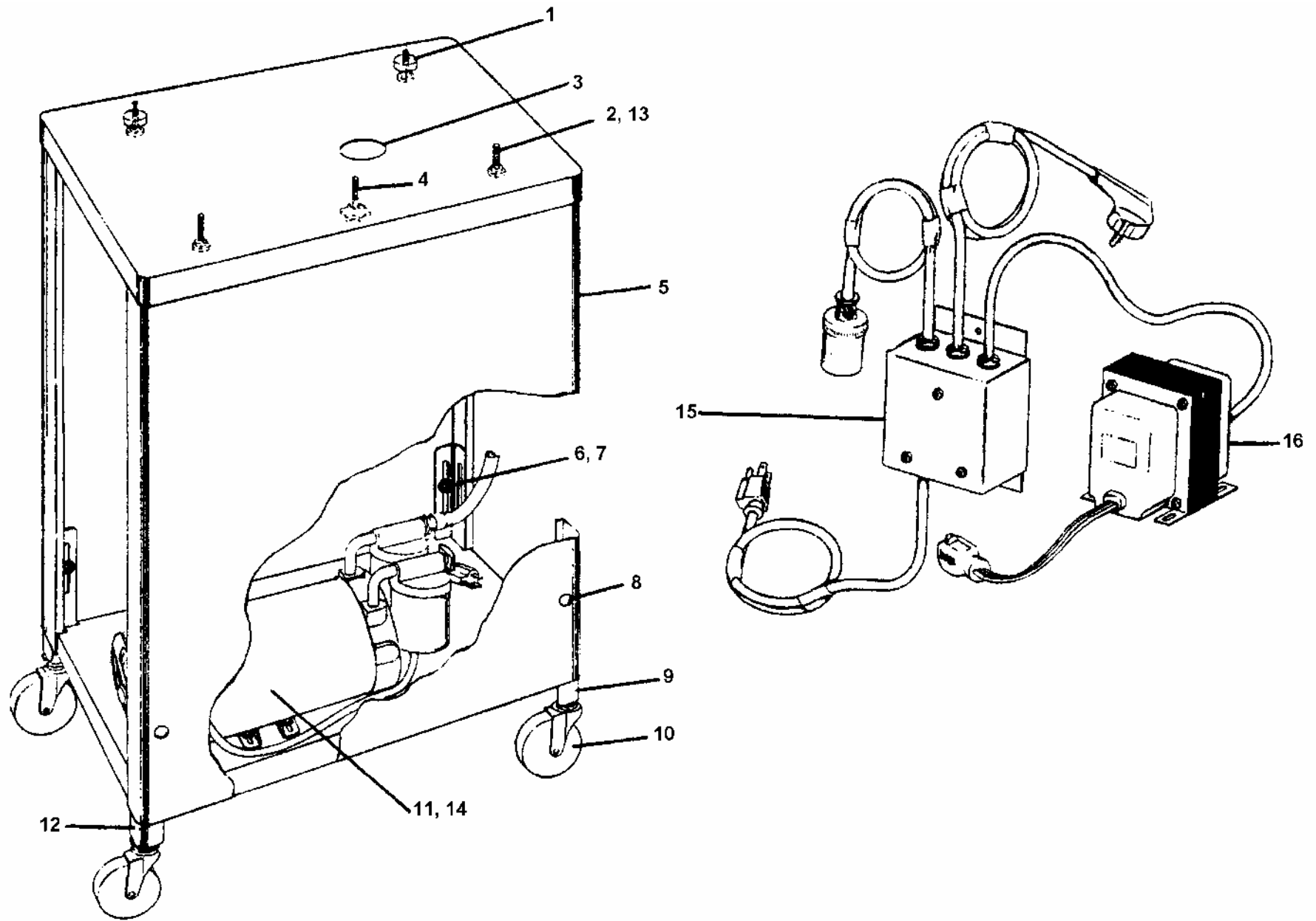

KEY #	PART #	DESCRIPTION	QTY.
1.	123-0208	PAD, RUBBER BASE	1
2.	80-108-20	LOCKING THUMBSCREW ASSEMBLY	4
3.	123-0394	GROMMET, CATERPILLAR	1
4.	80-108-22	LEVELING KNOB ASSEMBLY	1
5.	84-103-01	STAND WELDMENT	1
6.	123-0054	NUT, HEX 1/4-20	4
7.	123-0063	WASHER, 1/4 PLAIN	4
8.	123-0340	CARRIAGE BOLT 1/4-20 X 1/2	4
9.	84-103-05	BRACKET, WELDMENT R/H	2
10.	123-0093	CASTER ASSEMBLY	4
11.	84-103-07	VACUUM PUMP ASSEMBLY	1
12.	84-103-08	BRACKET, WELDMENT L/H	2
13.	123-0311	WASHER, PLASTIC	4
* 14.	84-103-10	VACUUM PUMP 220/50	1
* 15.	84-140-78	RELAY BOX 220/50	1
* 16.	123-0436	TRANSFORMER 220/50	1

*ITEMS 14, 15 and 16 ARE FOR 220 VOLT / 50 Hz.

GROUP 1A

GROUP 2

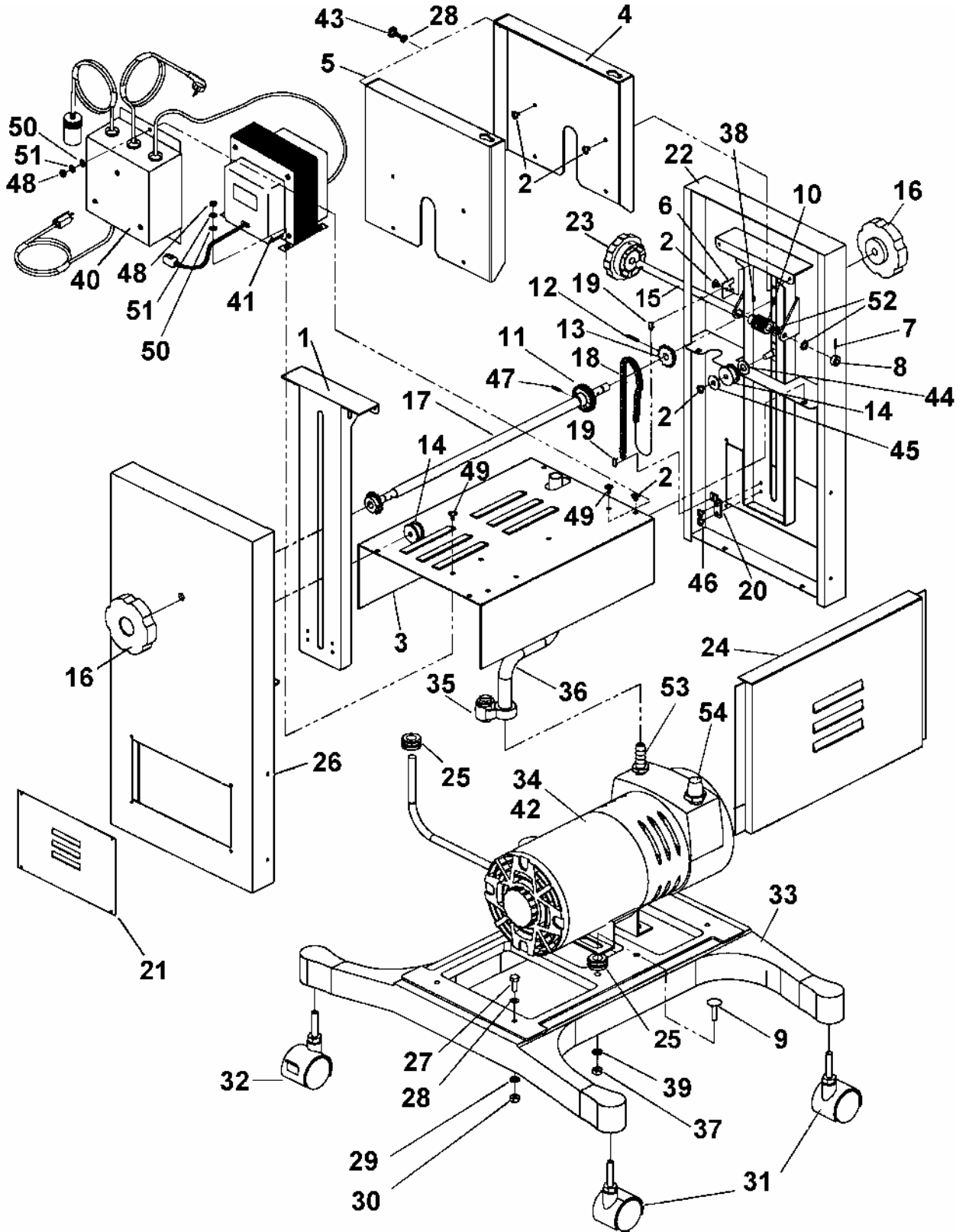

GROUP 2

KEY #	PART #	DESCRIPTION	QTY.
1.	156-102-18	ELEVATOR BRACKET (STANDARD)	2
1.	156-103-18	ELEVATOR BRACKET (LONG)	2
2.	123-0017	SCREW, 10-32X1/4 PHLPS TRUSS	32
3.	156-103-05	PANEL – BASE – PUMP COVER	1
4.	156-103-07	SIDE PLATE R/H	1
5.	156-103-06	SIDE PLATE L/H	1
6.	156-103-25	ELEVATOR BRACKET SUPPORT	2
7.	123-0695	SPRING PIN, 3/32 X 1/2	1
8.	156-103-27	COLLAR	1
9.	123-0841	CARRIAGE BOLT, 5/16 – 18 X 1	4
10.	156-103-12	HELIX ANGLE WORM	2
11.	156-103-11	WORM GEAR 20 TEETH	1
12.	123-0018	ROLL PIN 1/8 X 3/4 – BLACK	3
13.	156-103-08	SPROCKET 25B13	2
14.	156-103-09	IDLER PULLEY	2
15.	156-103-21	WORM SHAFT	1
16.	123-0135	KNOB	2
17.	156-103-20	DRIVE SHAFT	1
18.	156-103-26	CHAIN, TRANSMISSION ROLLER	2
19.	123-0200	CONNECTING LINK, CHAIN	4
20.	156-103-23	ELEVATOR BRACKET SUPPORT	2
21.	86-103-04	COVER, SIDE PANEL	2
22.	156-103-03	SIDE PANEL L/H	2
23.	123-0293	KNOB, HEIGHT ADJUSTMENT	1
24.	86-103-06	PUMP COVER, STAND	2
25.	123-0707	RUBBER GROMMET 1/2ID X 3/4OD	1
26.	156-103-04	SIDE PANEL R/H	1
27.	123-0143	SCREW, HEX 1/4-20 X 5/8	4
28.	123-0063	WASHER, 1/4 PLAIN-MOTOR & PUMP	8
29.	123-0064	WASHER, LOCK 1/4	8
30.	123-0054	NUT, HEX 1/4-20	8
31.	123-0517	CASTER, NON LOCKING	2
32.	123-0521	CASTER, LOCKING	2
33.	86-103-31	BASE WELDMENT	1
34.	84-103-07	VACUUM PUMP ASSEMBLY, 115 V	1
35.	123-0131	CLAMP, HOSE	1
36.	84-106-41	HOSE, PUMP	1
37.	123-0051	NUT, 5/16-18 HEX	4
38.	123-0757	SCREW, SET 6-23 X 1/4 STD CUP PT	4
39.	123-0855	WASHER, 5/16 LOCKING	4
* 40.	84-140-78	RELAY BOX 220V / 50 Hz	1
* 41.	123-0436	TRANSFORMER, 220V / 50 Hz	1
* 42.	84-103-10	VACUUM PUMP, 220V / 50 Hz	1
43.	56-108-22	THUMBSCREW	1
44.	123-0096	WASHER, PLASTIC 3/8 X 3/4 X 1/16	2
45.	123-0311	WASHER, 9/32 X 3/4 X 1/16 PLASTIC	2
46.	123-0701	SCREW, 10-32 X 3/16 PH TRUSS HD	4
47.	123-0034	ROLL PIN, 1/8 X 5/8	1
*48.	123-0050	NUT, 10-32 X 5/16 HEX ZINC	6
*49.	123-0024	SCREW, 10-32 X 3/8 PH TRUSS HD MS ZINC	6
*50.	123-0237	WASHER, STAR #10 EXTERNAL	6
*51.	123-0262	WASHER #10 3/16 X 3/8 X .032	6
52.	123-0312	WASHER, 5/16 X 1/2 X .030 PLASTIC	2
53.	123-0145	FITTING	1
54.	123-1936	FILTER/MUFFLER	1
**	K247	SERVICE KIT, OLD STYLE PUMP	
**	K478	SERVICE KIT, NEW STYLE PUMP	
**	AK524	FELT, NEW STYLE PUMP ONLY	

* 220V/0HZ ONLY

**PARTS NOT SHOWN

GROUP 3

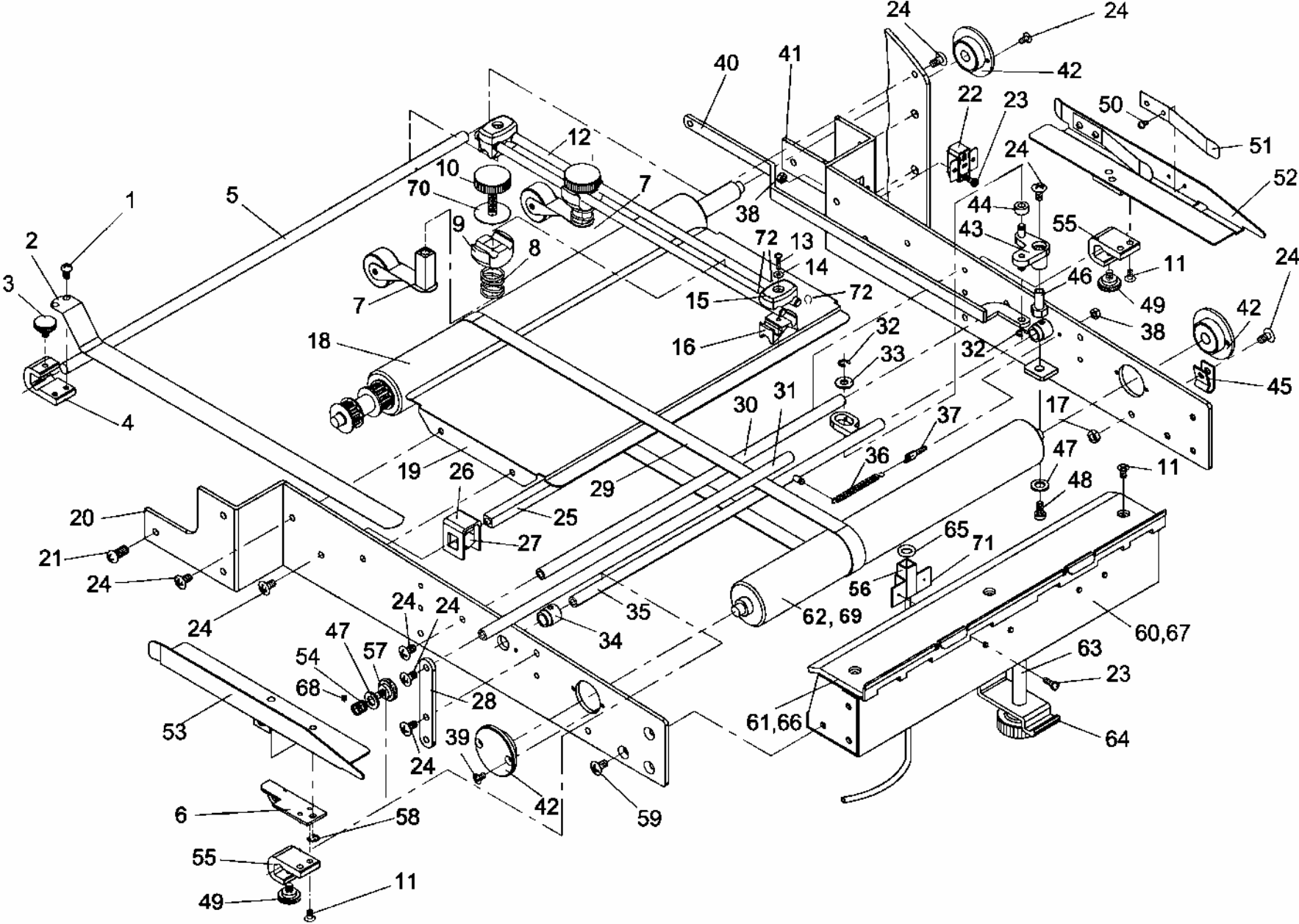

KEY #	PART #	DESCRIPTION	QTY.	KEY #	PART #	DESCRIPTION	QTY.
1.	123-0125	SCREW 8-32 X 3/16, BIN HD, PHIL	4	37.	123-0358	ANCHOR, JOGGER SPRING	1
2.	84-125-107	STRAP, PAPER RETAINER	2	38.	123-0192	NUT, 6-32 HEX	3
3.	71-109-07	THUMBSCREW ASSEMBLY	2	39.	123-0275	SCREW, OVAL CSK PH. 6-32X1/4	4
4.	71-125-21	CLAMP, RETAINER STRAP	2	40.	84-101-27	LINK JOGGER CONNECTING	1
5.	84-101-31	ROD, REAR SKID WHEEL SUPPORT	1	41.	84-101-12	FRAME, CONVEYOR L/H	1
6.	56-114-06	BRACKET-GUIDE, R/H	1	42.	84-121-12	BEARING CAP ASSEMBLY	2
7.	71-125-17	SKID ROLLER ASSEMBLY, SHORT	2	43.	80-112-03A	JOGGER LEVER ASSEMBLY	1
7.	86-125-46	SKID ROLLER ASSEMBLY LONG	1	44.	80-112-21	JOGGER LEVER BUSHING	1
8.	71-120-06	SPRING, SKID WHEEL	2	45.	123-0339	CLAMP, WIRE 3/16	2
9.	71-125-46	POST BRACKET	2	46.	80-112-04	PIVOT, JOGGER LEVER	1
10.	71-125-48	ADJUSTING SCREW ASSEMBLY	2	47.	123-0523	WASHER, 14 X 1/ X .032	2
11.	123-0446	SCREW, 8-32 X 5/16	7	48.	123-0185	SCREW, 10-32 X 3/8 SOCKET CAP	1
12.	71-125-47E	ROD, SKID WHEEL	2	49.	71-109-07	THUMBSCREW ASSEMBLY	2
13.	123-0241	SCREW, 4-40 X 7/16, BIN HD, PHIL	2	50.	123-0127	SCREW, 6-32 X 1/8	4
14.	123-0345	WASHER, PLAIN	2	51.	84-114-12	SPRING, SIDE GUIDE L/H	2
15.	71-125-37A	PLATE, SKID WHEEL CLAMP	2	* 52.	56-114-12	BODY L/H SIDE GUIDE ASSY.	1
16.	71-125-84	CLAMP ASSEMBLY, SKID WHEEL	2	* 53.	56-114-03	BODY R/H SIDE GUIDE ASSY.	1
17.	123-0050	NUT, 10-32 X 5/16 HEX, ZINC	2	54.	84-120-05	SPRING, COMPRESSION	1
18.	84-101-17	ROLLER ASSEMBLY, REAR	1	55.	56-114-17	CLAMP-GUIDE	2
19.	84-101-07	CENTER PLATE, CONVEYOR	1	56.	84-150-25	PHOTOSENSOR ASSEMBLY	1
20.	84-101-20B	FRAME, CONVEYOR R/H	1	57.	84-114-05	SCREW, R/H SIDE GUIDE ADJUSTING	1
21.	123-0276	SCREW, 1/4-20 X 1/2	6	58.	123-0099	TRUARC	1
22.	84-140-71	WIRE HARNESS, DUAL STREAM	1	59.	123-0017	SCREW, 10-32 X 1/4	10
23.	123-0280	SCREW, 6-32 X 3/8	2	60.	84-101-15	FRONT FEED PLATE ASSEMBLY	1
24.	123-0024	SCREW, 10-32 X 3/8, TRUSS PHIL.	44	61.	84-101-10	PAD, FRONT FEED PLATE	1
25.	84-101-29	ROD, TAPE GUIDE	1	62.	84-101-02	ROLLER ASSEMBLY, FRONT	1
26.	71-130-13	TAPE GUIDE, CONVEYOR	6	63.	84-101-16	SCREW, ASSEMBLY, FRONT CLAMP	1
27.	71-130-15	SPRING, TAPE GUIDE	6	64.	84-101-14	CLAMP, AB DICK FRONT PLATE	1
28.	84-101-24	BRACKET-FRONT SKID WHEEL ROD	2	65.	123-0472	O-RING, PHOTOSENSOR	1
29.	123-0107	TAPE, CONVEYOR	6	** 66.	84-101-10W	PAD, FRONT FEED PLATE WIDE	1
30.	84-101-26	ROD, CONVEYOR REAR TIE	1	** 67.	84-101-15W	FRONT FEED PLATE ASSEMBLY, WIDE	1
31.	84-101-19	ROD, FRONT SKID WHEEL	1	68.	123-0431	SCREW, SET 6-32 X 1/8 NYLON	1
32.	123-0080	TRUARC	2	69.	84-101-02W	FRONT CONVEYOR ROLLER – WIDE	1
33.	123-0100	WASHER 1/2 X .218 X .048 THICK	1	70.	123-0240	WASHER, PLAIN 7/8 X 17/64 X .032	2
34.	80-112-06	BUSHING, JOGGER ROD	2	71.	84-140-22	CLAMP - PHOTOCCELL MTG.	1
35.	84-101-25	JOGGER ROD ASSEMBLY	1	72.	123-0257	TRUARC	4
36.	80-120-25	SPRING, JOGGER	1				

* SEE GROUP 10 FOR ASSEMBLY

** REPLACEMENT FOR S/N 1149 AND BELOW.

GROUP 3

GROUP 4

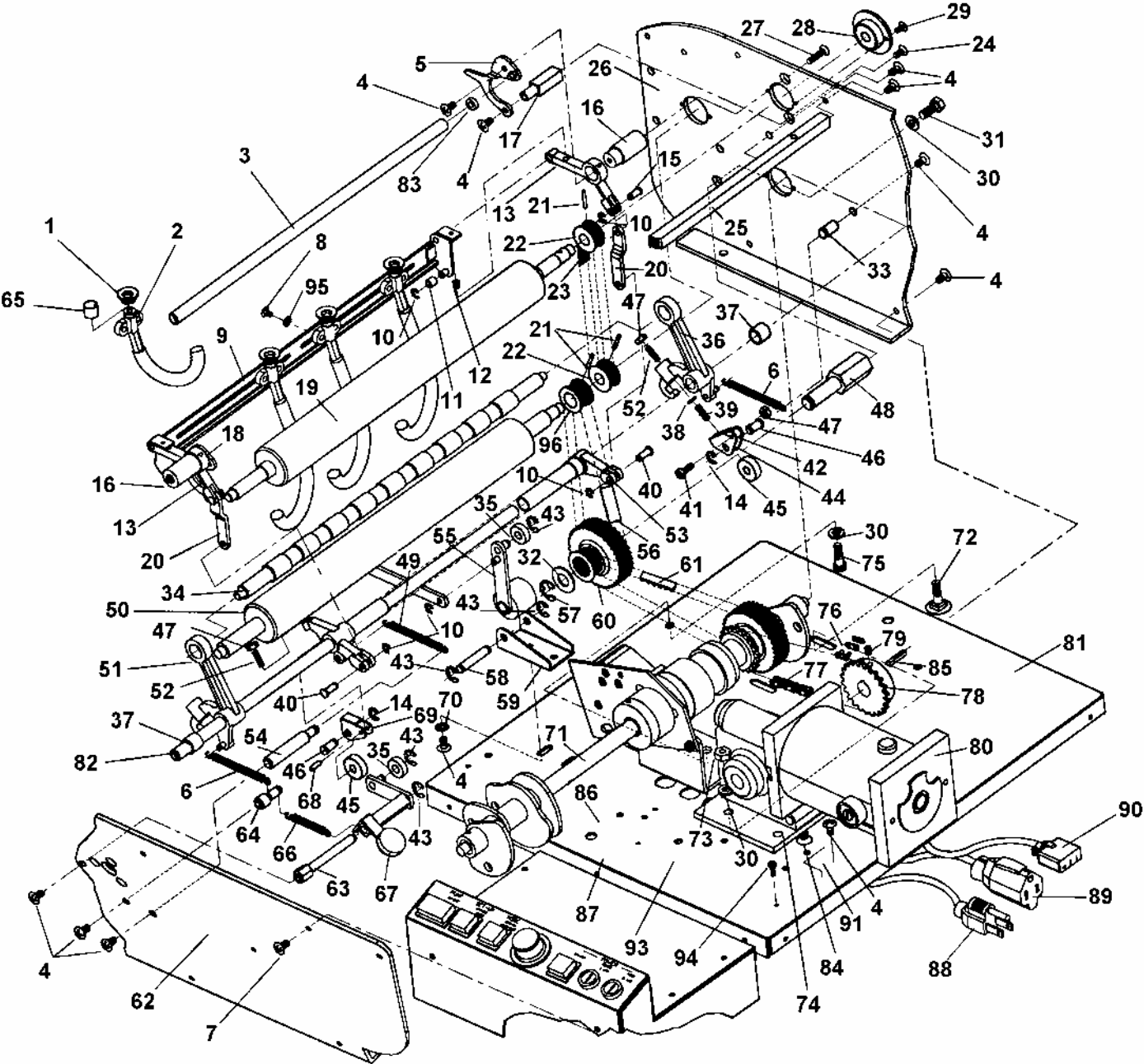

KEY #	PART #	DESCRIPTION	QTY.	KEY #	PART #	DESCRIPTION	QTY.
1.	71-134-15	SUCTION CUP	4	49.	84-120-10	SPRING, UPPER PULLOUT ROLLER	1
2.	84-105-22	FITTING ASSEMBLY, SUCTION CUP	4	50.	84-101-17	ROLLER, REAR CONVEYOR ASSEMBLY	1
3.	84-105-35	IDLER ROLLER ASSEMBLY	1	51.***	84-107-09	LEVER, PULLOUT ROLLER ASSEMBLY, L/H	1
4.	123-0024	SCREW, PHILLIPS TRUSS 10-32 X 3/8	23	52.	123-0374	SCREW,, SET-SOC. HD 10-32 X 1/2	3
5.	84-105-30	CAM ASSEMBLY, SUCTION CUP R/H	1	53.	84-104-00	OSCILLATING TUBE	1
6.	84-120-10	SPRING, UPPER PULLOUT ROLLER	2	54.	84-121-18	PIN, SUCTION CUP SPRING	1
7.	123-0017	SCREW, 10-32 X 1/4	3	55.	84-101-41	WELDMENT, JOGGER CAM FOLLOWER	1
8.	123-0274	SCREW, TRUSS HEAD PH 6-32 X 3/8	8	56.	123-0338	BELT, TIMING 100 XLO37	1
9.	84-105-08	CARRIAGE WELDMENT, SUCTION CUP	1	57.	123-0398	TRUARC	1
10.	123-0080	TRUARC	2	58.	84-101-46	PIN, JOGGER CAM FOLLOWER ARM	1
11.	84-105-12	BEARING, ROLLER ASSEMBLY	2	59.	84-101-45	BRACKET, JOGGER CAM FOLLOWER ARM	1
12.	71-120-09	SPRING, CARRIAGE TILT	2	60.	84-122-25	PULLEY COMBINATION ASSEMBLY	1
13.	84-105-36	ARM, SUCTION BAR	3	61.	123-0140	BELT TIMING 110 XLO37	1
14.****	123-0423	TRUARC	3	62.	84-100-01B	FRAME, L/H SIDE	1
15.	71-121-03	PIN, SHORT LINK	2	63.	84-106-19	PIVOT, VACUUM VALVE STOPPER	1
16.	84-105-01	PIVOT, SUCTION CUP LEVER	2	64.	84-106-20	PIN, VACUUM VALVE SPRING	1
17.	84-105-37	POST, SUCTION CUP CAM	2	65.	123-0415	SUCTION FOOT VACUUM CAP	4
18.	84-105-31	CAM ASSEMBLY, SUCTION CUP L/H	1	66.	71-120-01	SPRING, MAIN	1
19.	84-115-20	RUBBER ROLLER ASSEMBLY	1	67.	84-106-11	VACUUM VALVE ARM ASSEMBLY	1
20.	84-117-11	LINK, SUCTION CUP ARM	2	68.	123-0387	ROLL PIN, 1/8 X 7/16	1
21.	123-0036	ROLL PIN, 3/32 X 5/8	3	69.	84-104-06	HOUSING, OSCILLATING TUBE CAM FOLLOWER	1
22.	123-0102	PULLEY - PLASTIC, 12XLO.312	3	70.	123-0237	WASHER, #10 STAR	1
23.	123-0277	BELT, TIMING 110XLO31	1	71.	84-128-08	CAM SHAFT ASSEMBLY	1
24.	123-0002	SCREW, 10-32 X 3/8	2	72.	123-0471	CARRIAGE BOLT, 1/4-20	4
25.	84-106-28	HOSE SUPPORT WELDMENT	1	73.	123-0054	NUT, HEX 1/4-20	2
26.	84-100-02B	FRAME, R/H SIDE	1	74.	80-100-34	PLATE, MOTOR MOUNTING	1
27.	123-0003	SCREW, 10-32 X 3/4	2	75.	123-0182	SCREW, SOC. CAP HEAD 1/4-20 X 3/4	2
28.	84-121-12	BEARING CAP ASSEMBLY	6	76.	123-0200	CONNECTING LINK, CHAIN	1
29.	123-0275	SCREW, 6-32 X 1/4	12	77.	123-0199	CHAIN	1
30.	123-0064	WASHER, LOCK 1/4	7	78.	84-122-22	SPROCKET 22 TEETH	1
31.	123-0143	SCREW, 1/4-20 X 5/8	1	79.	123-0001	SET SCREW, 10-32 X 1/4	1
32.	123-0399	WASHER, 7/16 X 7/8 X 1/16	1	80.	123-0082C	MOTOR	1
33.	71-121-05	PIN, PULLOUT ROLLER SPRING	1	81.	84-100-62	MOTOR BASE	1
34.	84-107-06	ROLLER, UPPER PULLOUT	1	82.	84-104-07	SHAFT, OSCILLATING TUBE	1
35.****	123-0035	BEARING	2	83.	123-0077	BEARING, IDLER ROLLER	2
36.***	84-107-08	LEVER ASSY R/H, PULLOUT ROLLER	1	84.	123-0263	SCREW, 1/4-20 X 5/8	4
37.	84-102-10	SPACER, OSCILLATING TUBE	1	85.	123-0497	KEY, 1/8 X 1/8 X 3/4	1
38.****	123-0375	WASHER, 5/16 X 1/8 X 1/32	2	86.	84-140-71	WIRE HARNESS, DUAL STREAM	1
*39.****	84-120-26A	SPRING, PULL OUT ROLLER ARM	2	87.	84-140-73	WIRE HARNESS, SOLENOID	1
*39.****	84-120-26B	SPRING, PULL OUT ROLLER ARM	2	88.	84-140-74	POWER CORD	1
40.	71-121-06	PIN, LONG LINK	2	89.	84-140-75	POWER CORD RECEPTACLE, PUMP	1
41.****	123-0008	SCREW, PHILLIPS BUTTON-HEAD 10-32X1/2	2	90.	84-140-72	HARNESS, TIMING CABLE ASSEMBLY	1
42.	84-107-14	BUSHING, PULL OUT ROLLER LEVER	2	91.	123-0196	WIRE CLAMP	3
43.	123-0081	TRUARC	5	92.	123-0394	GROMMET	1
44.****	84-107-13	HOUSING, PULL OUT ROLLER CAM FOLLOWER	2	93.	123-0350	TERMINAL BLOCK	1
45.****	123-0371	BEARING	3	94.	123-0280	SCREW, 6-32 X 3/8	2
46.****	84-107-12	PIVOT, PULL OUT ROLLER ARM	3	95.	123-0252	WASHER, #6 STAR	8
47.****	123-0050	NUT, 10-32 X 5/16 HEX, ZINC	5	96.	84-101-18	PULLEY, 12XLO	1
48.	84-100-54	STUD, DOUBLE PULLEY	1	**	123-0236R	MOTOR BRUSHES	

*BOTH SPRINGS MUST BE ORDERED B FITS INSIDE A

**NOT SHOWN IN ILLUSTRATION

*** Parts marked with **** are included with 84-107-09 and 84-107-08

GROUP 4

GROUP 5

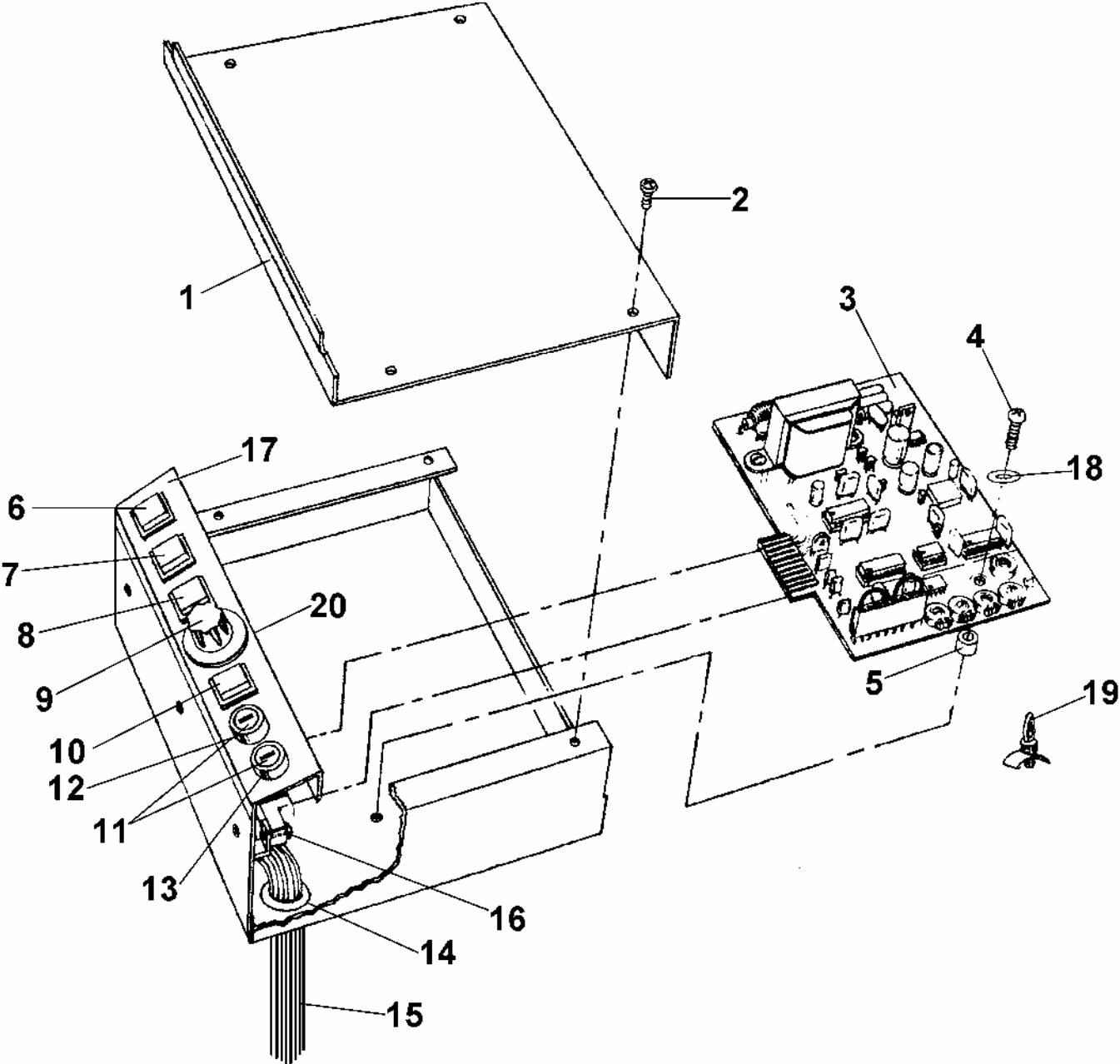

KEY #	PART #	DESCRIPTION	QTY.
1.	84-140-66	COVER, CONTROL BOX	1
2.	123-0125	SCREW, 8-32 X 3/16 PHILLIPS	4
3.	84-100-100	PC BOARD AB DICK, CONSOLE	1
3.	84-100-001	PC BOARD HAMADA 601, 602	1
3.	84-100-002	PC BOARD RYOBI 2700, 2800, 3200, ITEK 960, 975, 985	1
3.	84-100-003	PC BOARD MULTI 1218, TOKO 4700, 4700CD	1
3.	84-100-004	PC BOARD MULTI 1250, 1300, 1650	1
3.	84-100-005	PC BOARD RYOBI 3302, ITEK 2985	1
3.	84-100-006	PC BOARD HAMADA 500, 600, 660, 665	1
3.	84-100-008	PC BOARD HAMADA 611, 612, 661, 662	1
3.	84-100-012	PC BOARD HAMADA 47	1
3.	84-100-014	PC BOARD HEIDELBERG QUICKMASTER	1
3.	84-100-015	PC BOARD HAMADA H234	1
3.	84-100-016	PC BOARD HAMADA RS34, VS34	1
3.	84-100-017	PC BOARD HEIDELBERG PRINTMASTER	1
3.	84-100-018	PC BOARD ABDICK 9920	1
4.	123-0229	SCREW, 8-32 X 5/8	2
5.	123-0299	SPACER, PLASTIC	2
6.	123-0450	SWITCH, PUMP (FOR S/N 1223 & UP)	1
6.	123-0352	SWITCH, PUMP (FOR S/N 1000-1222)	1
7.	123-0354	SWITCH, MANUAL (BLACK)	1
8.	123-0353	SWITCH, MODE (BLACK)	1
9.	123-0390	KNOB, SPEED CONTROL	1
10.	123-0351	SWITCH, ON/OFF (RED)	1
11.	123-0355	FUSE HOLDER	2
12.	123-0285	FUSE, 2 AMP FAST BLOW	1
13.	123-0090	FUSE, 10 AMP SLO BLO	1
14.	123-0377	GROMMET	1
15.	84-140-70	WIRE HARNESS ASSEMBLY	1
16.	123-0241	SCREW, 4-40 X 7/16	2
17.	123-0408	DECAL, CONTROL PANEL	1
18.	123-0114	PLASTIC WASHER	2
19.	123-0426	SUPPORT, PC BOARD	2
20.	84-140-70P	POTENTIOMETER, SPEED CONTROL (50k)	1

GROUP 5

GROUP 6

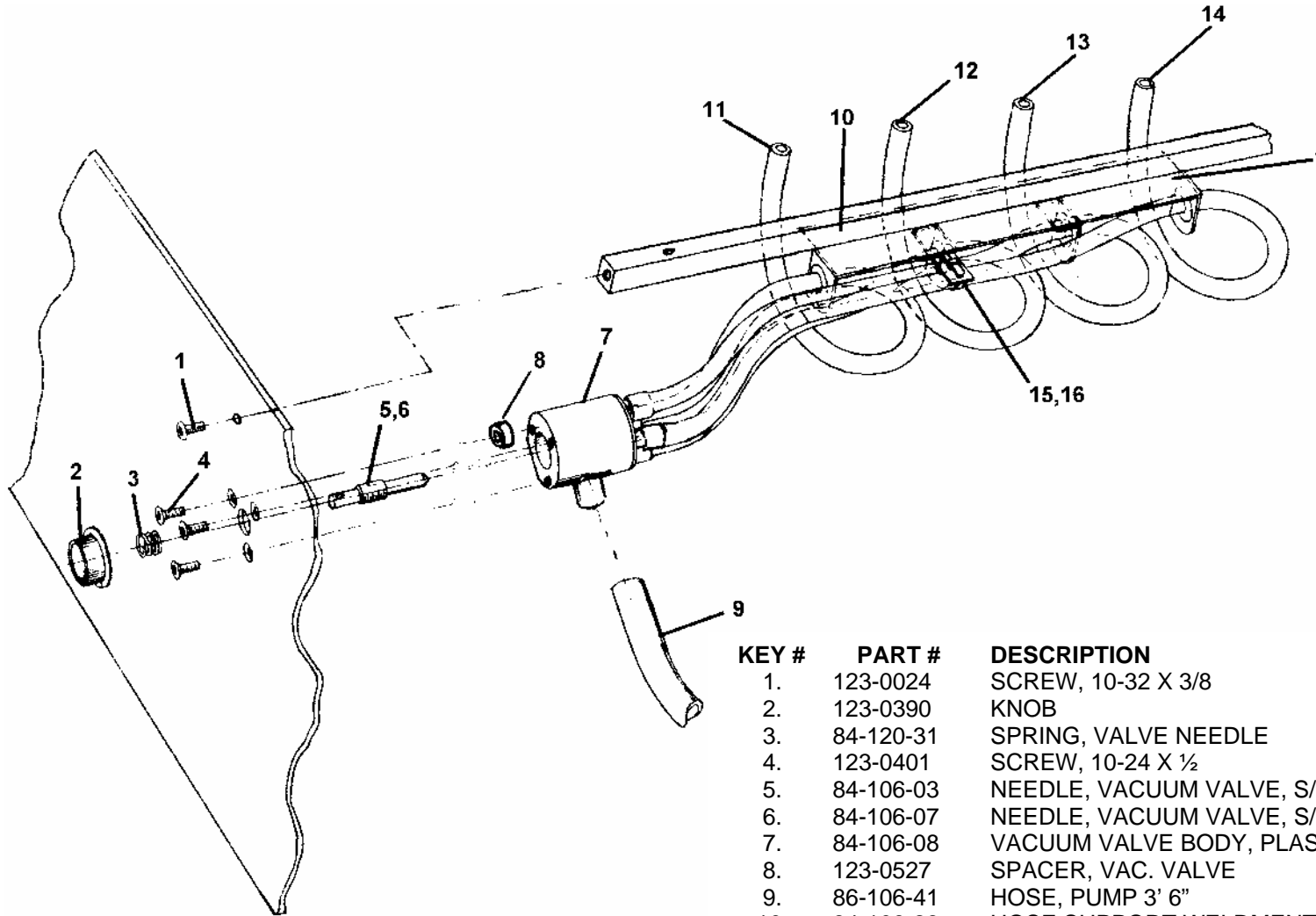

KEY #	PART #	DESCRIPTION	QTY.
1.	123-0024	SCREW, 10-32 X 3/8	2
2.	123-0390	KNOB	1
3.	84-120-31	SPRING, VALVE NEEDLE	1
4.	123-0401	SCREW, 10-24 X 1/2	3
5.	84-106-03	NEEDLE, VACUUM VALVE, S/N 2392 AND LOWER	1
6.	84-106-07	NEEDLE, VACUUM VALVE, S/N 2393 AND HIGHER	1
7.	84-106-08	VACUUM VALVE BODY, PLASTIC	1
8.	123-0527	SPACER, VAC. VALVE	3
9.	86-106-41	HOSE, PUMP 3' 6"	1
10.	84-106-28	HOSE SUPPORT WELDMENT	1
11.	84-106-40A	HOSE, SUCTION CUP 10 1/4 INCH	1
12.	84-106-40B	HOSE, SUCTION CUP 13 1/4 INCH	1
13.	84-106-40C	HOSE, SUCTION CUP 15 1/2 INCH	1
14.	84-106-40D	HOSE, SUCTION CUP 16 3/4 INCH	1
15.	123-0092	GROMMET, 11/32	4
16.	123-0113	PLASTIC TIE	1

GROUP 7

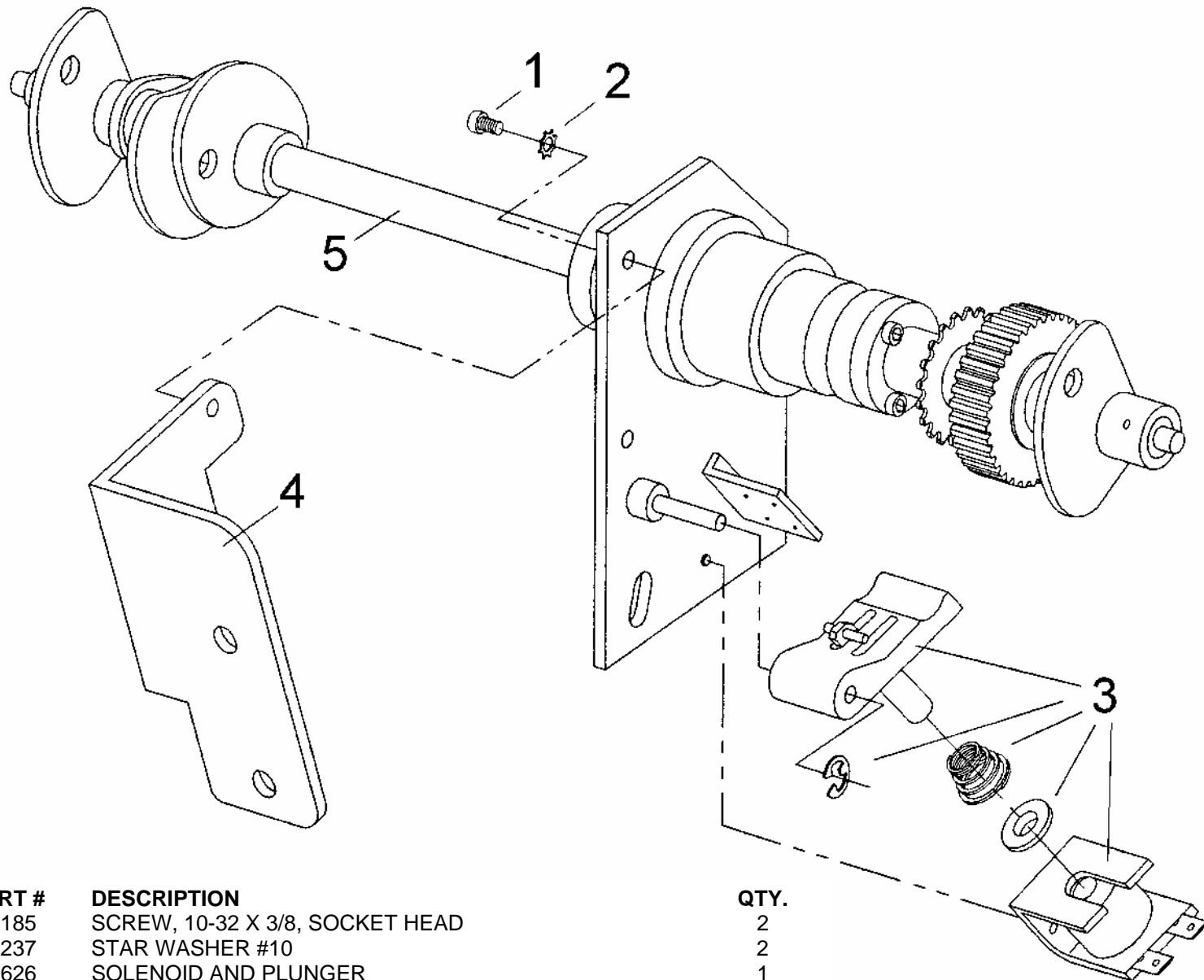

KEY #	PART #	DESCRIPTION	QTY.
1.	123-0185	SCREW, 10-32 X 3/8, SOCKET HEAD	2
2.	123-0237	STAR WASHER #10	2
3.	123-1626	SOLENOID AND PLUNGER	1
4.	84-128-80	CLUTCH MOUNTING BRACKET	1
5.	84-128-08	CLUTCH ASSEMBLY (INCLUDES ALL PARTS ABOVE)	1

GROUP 8

KEY	PART NUMBER	DESCRIPTION	QTY
1.	84-100-82	PAPER BOARD STOP	1
2.	84-140-01	MOUNTING PLATE WELDMENT	1
3.	123-0274	SCREW, TRUSS HEAD PH 6-32 X 3/8	2
4.	84-140-13	P.C. BOARD ASSY PULSE GENERATOR	1
5.	84-140-07	GEAR ASSEMBLY, MAGNETIC DRIVE, AB DICK	1
6.	123-0076	BUSHING, BRONZE 1/4 X 3/8	2
7.	123-0081	TRUARC, 5133-25	1
8.	123-0063	WASHER, 1/4 PLAIN	1
9.	84-101-51	BRACKET, PRESS SIDE GUIDE	1
10.	84-101-49	NUT, PRESS SIDE GUIDE STOP	1
11.	123-0311	WASHER, 9/32 X 3/4 X 1/16 PLASTIC	2
12.	84-140-00	PULSE GENERATOR ASSEMBLY	1
13.	123-0194	PLUG, 3-PRONG MALE	1
*	123-0195	PLUG 3-PRONG FEMALE	1

* NOT SHOWN

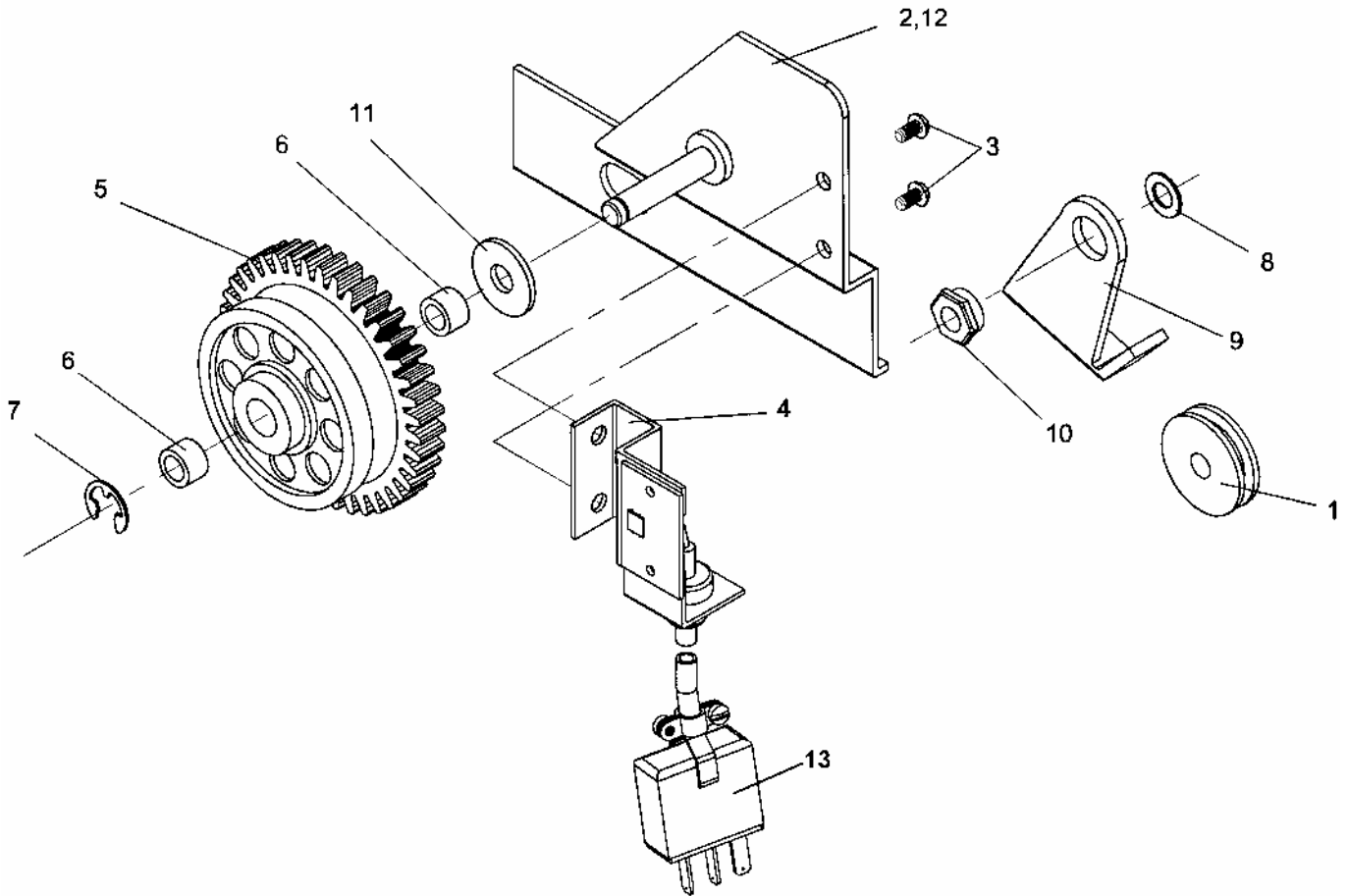

GROUP 9

REPLACEMENT PARTS FOR AB DICK CONVERSION KIT A-201

KEY	PART NUMBER	DESCRIPTION	QTY
*1.	84-100-82	PAPER BOARD STOP	1
2.	84-140-01	MOUNTING PLATE WELDMENT	1
3.	123-0274	SCREW, TRUSS HEAD PH 6-32 X 3/8	2
4.	84-140-13	P.C. BOARD ASSY PULSE GENERATOR	1
5.	84-140-07	GEAR ASSEMBLY, MAGNETIC DRIVE	1
6.	123-0076	BUSHING, BRONZE 1/4 X 3/8	2
7.	123-0081	TRUARC, 5133-25	1
*8.	123-0063	WASHER, 1/4 PLAIN	1
*9.	84-101-51	BRACKET, PRESS SIDE GUIDE	1
*10.	84-101-49	NUT, PRESS SIDE GUIDE STOP	1
11.	123-0311	WASHER, 9/32 X 3/4 X 1/16 PLASTIC	2
*12.	84-140-00	PULSE GENERATOR ASSEMBLY	1
13.	84-101-15	FRONT FEED PLATE ASSEMBLY	1
14.	84-101-10	PAD, FRONT FEED PLATE	1
15.	123-0446	SCREW, 8-32 X 5/16	1
16.	84-101-14	CLAMP, AB DICK FRONT PLATE	1
17.	84-101-16	SCREW, ASSEMBLY, FRONT CLAMP	1
18.	84-140-77	JUMPER PLUG, AB DICK	1
*19.	123-0113	PLASTIC TIES	4

* REPLACEMENT PARTS FOR AB DICK AUXILIARY INSTALLATION KIT A-202

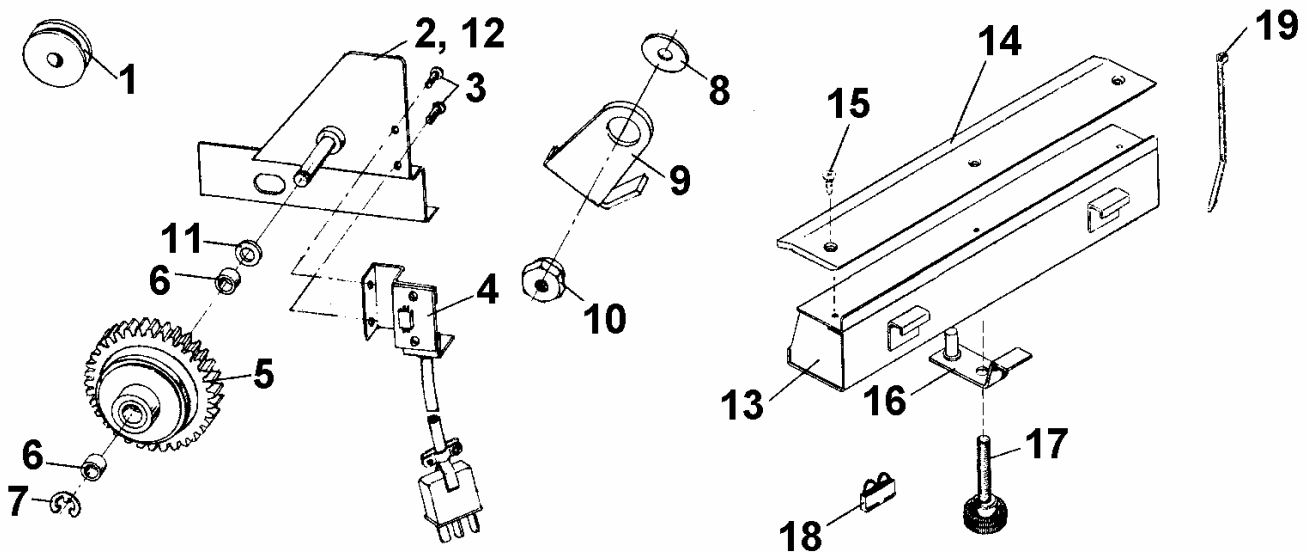

GROUP 10

REPLACEMENT PARTS FOR DUAL STREAM FEED KIT

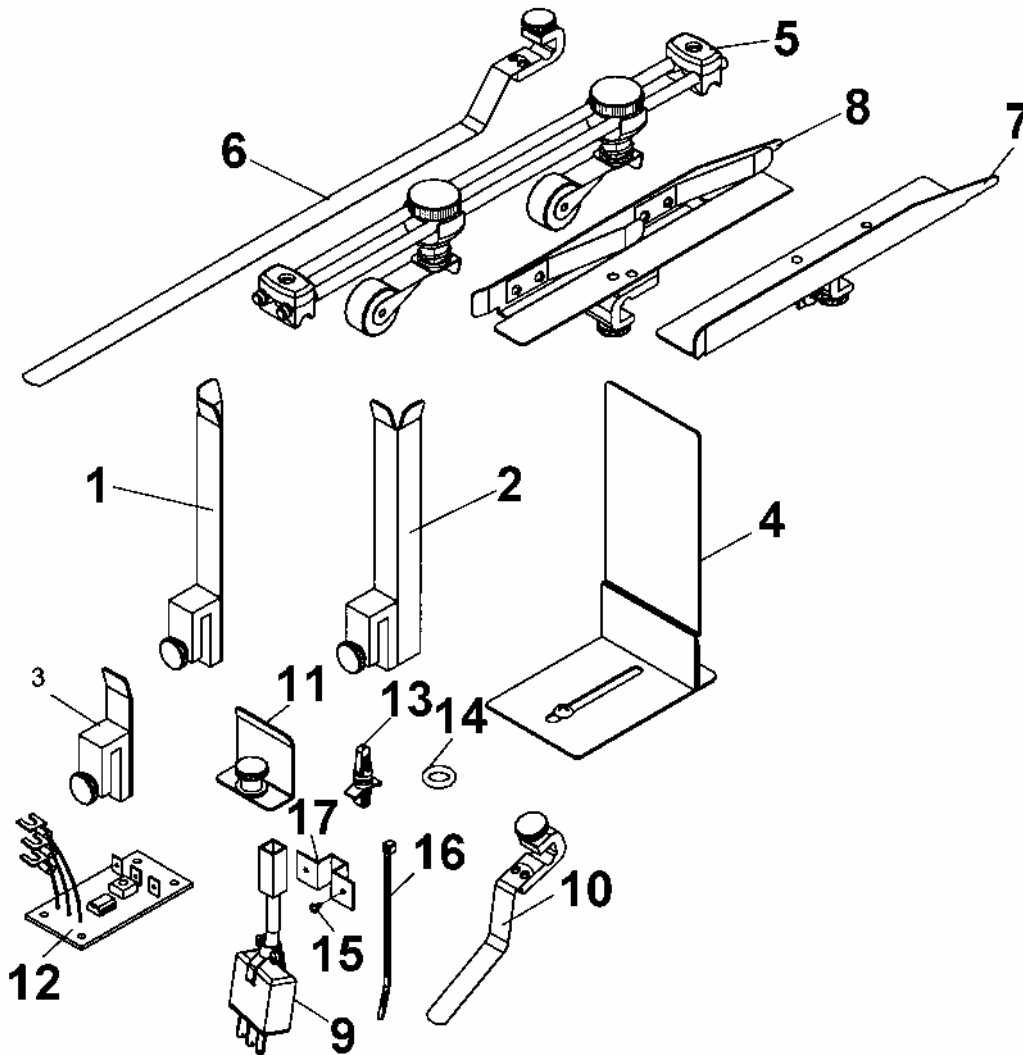

KEY #	PART #	DESCRIPTION	QTY.
1.	71-140-08	FRONT R/H ENVELOPE GUIDE ASSEMBLY	1
2.	71-140-10	FRONT L/H ENVELOPE GUIDE ASSEMBLY	1
3.	71-140-13	CENTER GUIDE ASSEMBLY	1
4.	84-108-20	REAR ENVELOPE GUIDE ASSEMBLY	1
5.	84-130-20	SKID WHEEL ASSEMBLY	1
6.	84-125-108	RETAINER STRAP ASSEMBLY	2
7.	56-114-03	SIDE GUIDE ASSEMBLY R/H	1
8.	56-114-04	SIDE GUIDE ASSEMBLY L/H	1
9.	84-140-20	PHOTOSENSOR, DUAL STREAM	1
10.	84-125-110	FRONT RETAINER STRAP ASSEMBLY	1
11.	84-100-15	GUIDE ASSEMBLY, ANTI SKEWING	2
12.	84-140-12	P.C. BOARD, DUAL STREAM	1
13.	123-0426	SUPPORT, P.C. BOARD	4
14.	123-0472	O-RING, PHOTOSENSOR	1
15.	123-0280	SCREW, 6-32 X 3/8	2
16.	123-0113	PLASTIC TIES	1
17.	84-140-22	CLAMP - PHOTOCCELL MTG.	1

GROUP 11

REPLACEMENT PARTS FOR HAMADA 500, 600, 660, AND 665 CONVERSION KIT A-213

KEY	PART NUMBER	DESCRIPTION	QTY
1.	89-101-15	WELDMENT, FRONT FEED PLATE	1
2.	87-101-10	PAD, FRONT FEED PLATE	1
3.	123-0446	SCREW	3
4.	89-101-14	CLAMP, FRONT FEED PLATE	1
5.	87-101-39	SLEEVE, CLAMP SCREW	1
6.	87-101-16	SCREW ASSEMBLY, CLAMP	1
*7.	123-0113	PLASTIC TIES	4
*8.	89-100-82	PAPER BOARD STOP	1
*9.	89-140-100	PULSE GENERATOR ASSEMBLY	1
10.	89-140-101	SENSOR BRACKET	1
11.	89-140-113	SENSOR ASSEMBLY	1
12.	123-0274	SCREW, 6-32	2
13.	123-0252	WASHER, STAR #6	2
14.	89-140-107	MAGNET ASSEMBLY	1
15.	123-0311	WASHER, PLASTIC	1
16.	123-0081	TRUARC	1
17.	89-140-77	JUMPER PLUG – HAMADA	1

* REPLACEMENT PARTS FOR HAMADA 600 AUXILIARY INSTALLATION KIT A-214

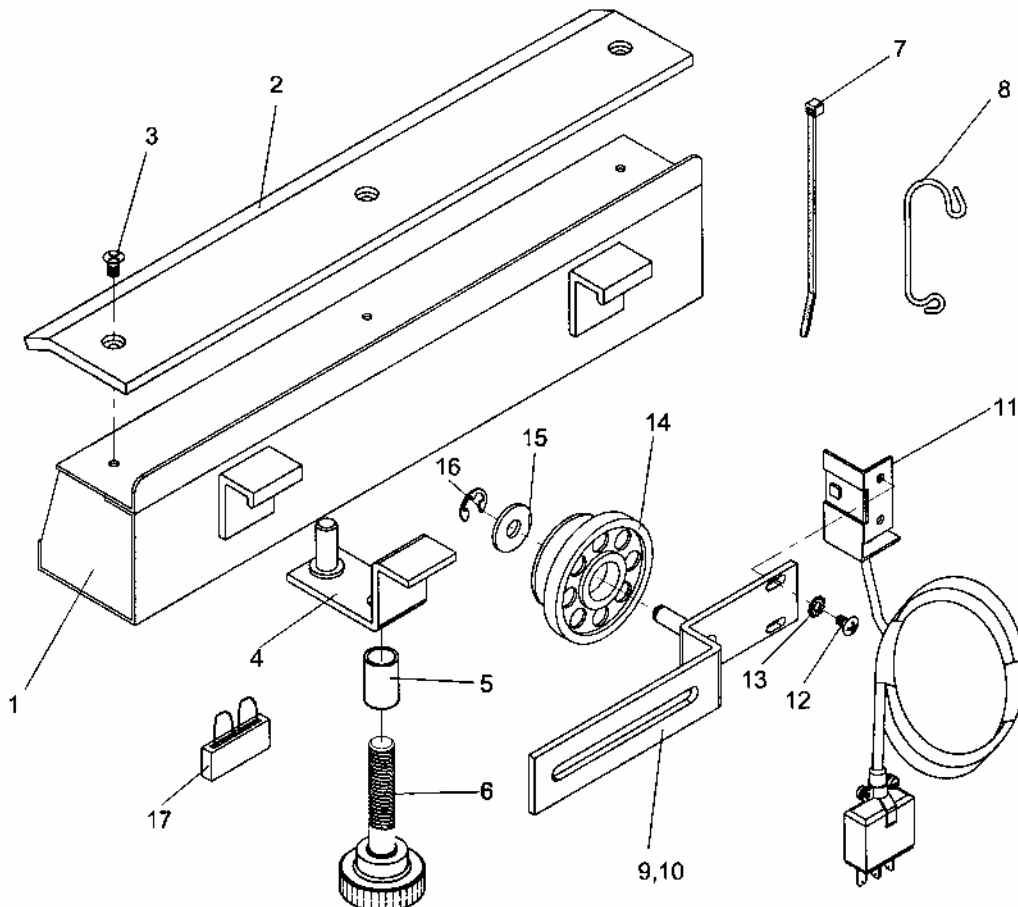

GROUP 12

REPLACEMENT PARTS FOR HAMADA 601/602 CONVERSION KIT A-204

KEY	PART NUMBER	DESCRIPTION	QTY
1.	89-101-15	WELDMENT, FRONT FEED PLATE	1
2.	87-101-10	PAD, FRONT FEED PLATE	1
3.	123-0446	SCREW	3
4.	89-101-14	CLAMP, FRONT FEED PLATE	1
5.	87-101-39	SLEEVE, CLAMP SCREW	1
6.	87-101-16	SCREW ASSEMBLY, CLAMP	1
*7.	123-0113	PLASTIC TIES	4
*8.	89-100-82	PAPER BOARD STOP	1
*9.	89-140-00	PULSE GENERATOR ASSEMBLY	1
10.	89-140-01	SENSOR BRACKET	1
11.	89-140-13	SENSOR ASSEMBLY	1
12.	123-0274	SCREW, 6-32	2
13.	123-0252	WASHER, STAR #6	2
14.	89-140-07	MAGNET ASSEMBLY, HAMADA	1
15.	123-0081	TRUARC	1
16.	87-140-77	JUMPER PLUG – HAMADA	1

* REPLACEMENT PARTS FOR HAMADA 601/602 AUXILIARY INSTALLATION KIT A-205

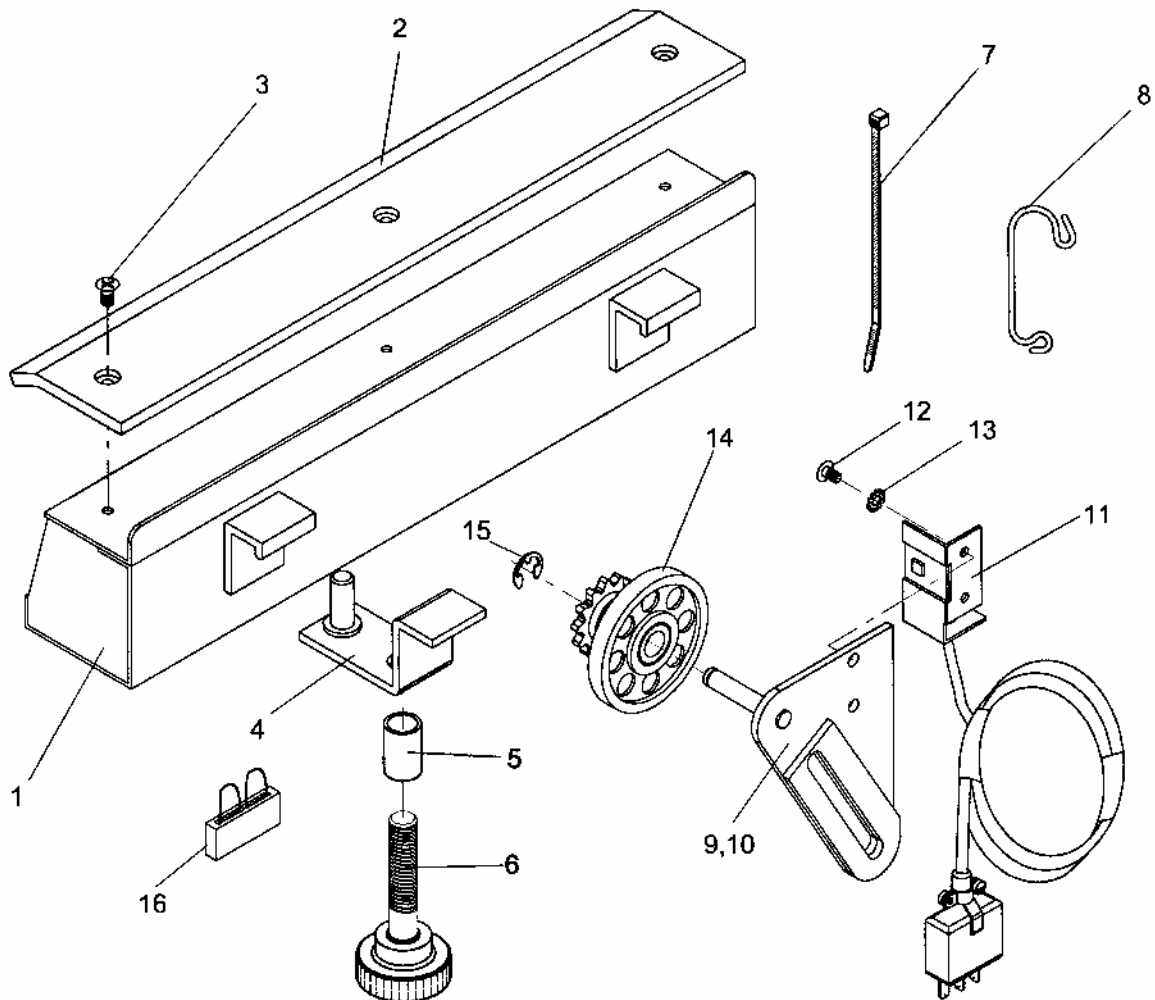

GROUP 13

REPLACEMENT PARTS FOR HAMADA 611/612 CONVERSION KIT A-210

KEY	PART NUMBER	DESCRIPTION	QTY
1.	89-101-15	WELDMENT, FRONT FEED PLATE	1
2.	87-101-10	PAD, FRONT FEED PLATE	1
3.	123-0446	SCREW	3
4.	89-101-14	CLAMP, FRONT FEED PLATE	1
5.	87-101-39	SLEEVE, CLAMP SCREW	1
6.	87-101-16	SCREW ASSEMBLY, CLAMP	1
*7.	123-0113	PLASTIC TIES	4
*8.	89-100-82	PAPER BOARD STOP	1
*9.	89-140-200	PULSE GENERATOR ASSEMBLY	1
10.	89-140-201	SENSOR BRACKET	1
11.	89-140-213	SENSOR ASSEMBLY	1
12.	123-0274	SCREW, 6-32	2
13.	123-0252	WASHER, STAR #6	2
*14.	89-140-207	MAGNET ASSEMBLY	1
*15.	123-0311	WASHER, PLASTIC	1
16.	123-0081	TRUARC	1
17.	87-140-77	JUMPER PLUG – HAMADA	1

* REPLACEMENT PARTS FOR HAMADA 611/612 AUXILIARY INSTALLATION KIT A-212

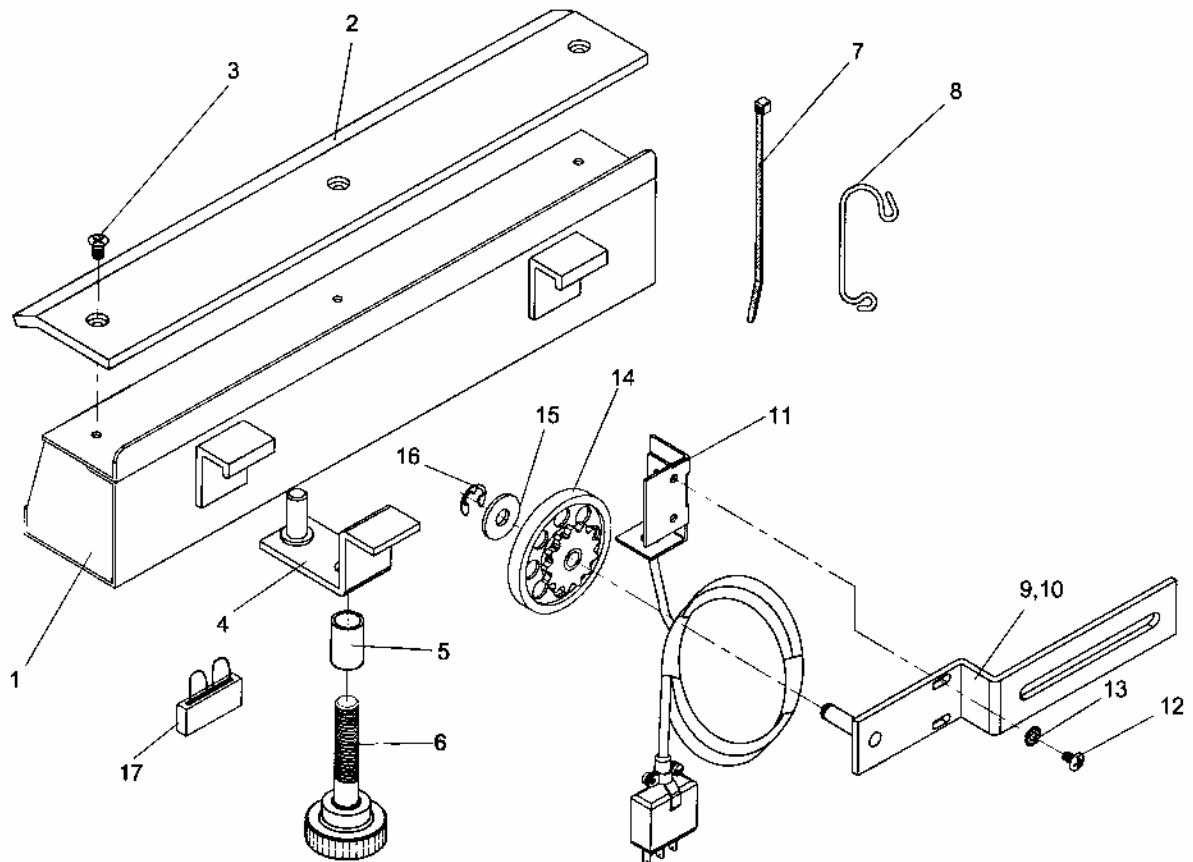

GROUP 14

REPLACEMENT PARTS FOR RYOBI 2700, 2800, 3200 CONVERSION KIT A-206

KEY	PART NUMBER	DESCRIPTION	QTY
1.	88-101-15	WELDMENT, FRONT FEED PLATE	1
2.	87-101-10	PAD, FRONT FEED PLATE	1
3.	123-0446	SCREW	3
4.	88-101-14	CLAMP, FRONT FEED PLATE	1
5.	87-101-39	SLEEVE, CLAMP SCREW	1
6.	87-101-16	SCREW ASSEMBLY, CLAMP	1
*7.	123-0113	PLASTIC TIES	4
*8.	88-100-82	PAPER BOARD STOP	1
*9.	88-140-08	SENSOR BRACKET ASSEMBLY	1
10.	88-140-02	SENSOR BRACKET	1
11.	88-140-13	SENSOR ASSEMBLY	1
12.	123-0274	SCREW, 6-32	2
13.	123-0252	WASHER, STAR #6	2
*14.	88-140-07	MAGNET ASSEMBLY, RYOBI	1
*15.	123-0256	SET SCREW	1
16.	88-140-77	JUMPER PLUG – RYOBI	1

* REPLACEMENT PARTS FOR RYOBI AUXILIARY INSTALLATION KIT A-207

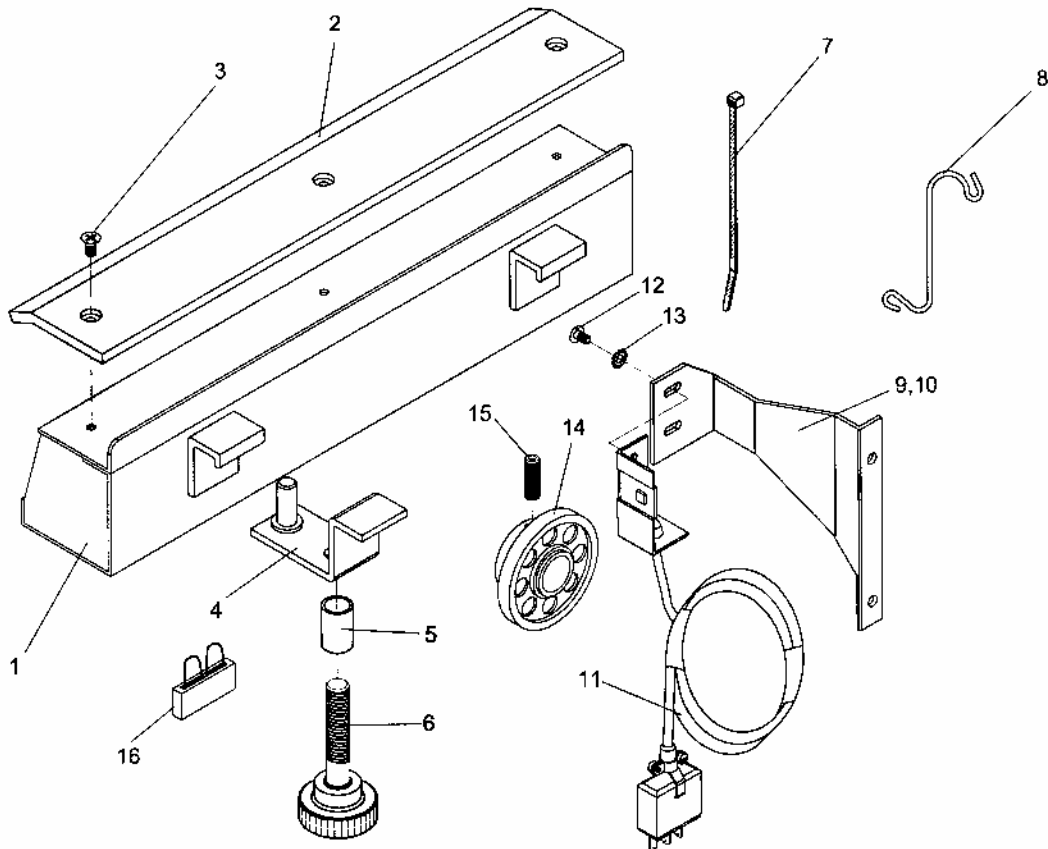

GROUP 15

REPLACEMENT PARTS FOR MULTI 1218, IMPERIAL, TOKO 4700 AND 4700CD CONVERSION KIT A-208

KEY	PART NUMBER	DESCRIPTION	QTY
1.	87-101-15	WELDMENT, FRONT FEED PLATE	1
2.	87-101-10	PAD, FRONT FEED PLATE	1
3.	123-0446	SCREW #6-32 X 5/16	3
4.	87-101-14	CLAMP, FRONT FEED PLATE	1
5.	87-101-39	SLEEVE, CLAMP SCREW	1
6.	87-101-16	SCREW ASSEMBLY, CLAMP	1
*7.	123-0113	PLASTIC TIES	4
*8.	89-100-82	PAPER BOARD STOP	1
*9.	87-140-08	SENSOR BRACKET ASSEMBLY	1
10.	87-140-02	SENSOR BRACKET	1
11.	87-140-13	SENSOR ASSEMBLY	1
12.	123-0274	SCREW, 6-32	2
13.	123-0252	WASHER, STAR #6	2
*14.	87-140-07	MAGNET ASSEMBLY, IMPERIAL	1
*15.	123-0256	SET SCREW	1
16.	88-140-77	JUMPER PLUG – IMPERIAL	1

* REPLACEMENT PARTS FOR IMPERIAL AUXILIARY INSTALLATION KIT A-209

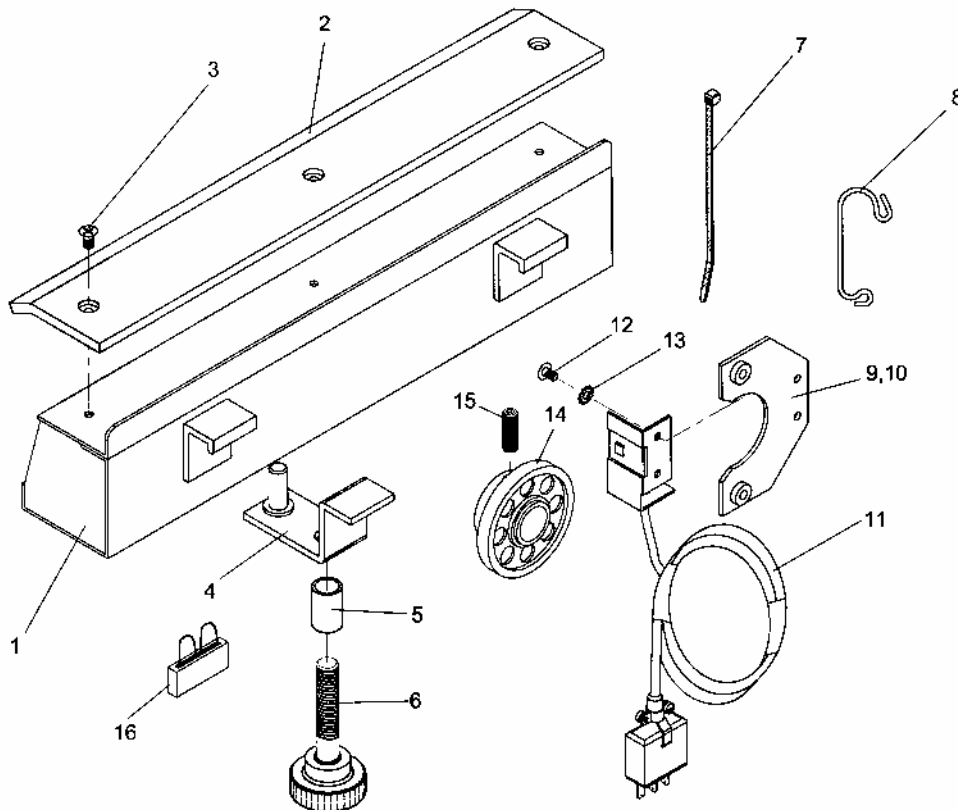

GROUP 16

REPLACEMENT PARTS FOR ADJUSTING SENSOR KIT P/N 84-160-10

KEY	PART NUMBER	DESCRIPTION	QTY
1.	84-100-00A	P.C. BOARD, DARK ENVELOPE KIT	1
*2.	84-140-84	POTENTIOMETER ASSEMBLY	1
*3.	80-120-24	SPRING	1
*4.	123-0057	ALLEN WRENCH 1/16	1
*5.	123-0096	PLASTIC WASHER	1
*6.	123-0305	INDICATOR PLATE	1
*7.	123-0390	KNOB	1
8.	84-140-77	JUMPER PLUG	1
	84-160-11	ADJUSTING SENSOR KIT #2 – INCLUDES ALL PARTS MARKED WITH ASTERISK (*) PLUS CUSTOMER'S GOOD P.C. BOARD CONVERTED TO PART NUMBER 84-100-00A	1
	84-160-12	ADJUSTING SENSOR KIT #3 – INCLUDES ALL PARTS MARKED WITH ASTERISK (*) PLUS CUSTOMER'S DEFECTIVE P.C. BOARD, REPAIRED AND CONVERTED TO PART NUMBER 84-100-00A. THE COST OF REPLACEMENT COMPONENTS ON DEFECTIVE P.C. BOARD WILL BE AN ADDITIONAL CHARGE.	1

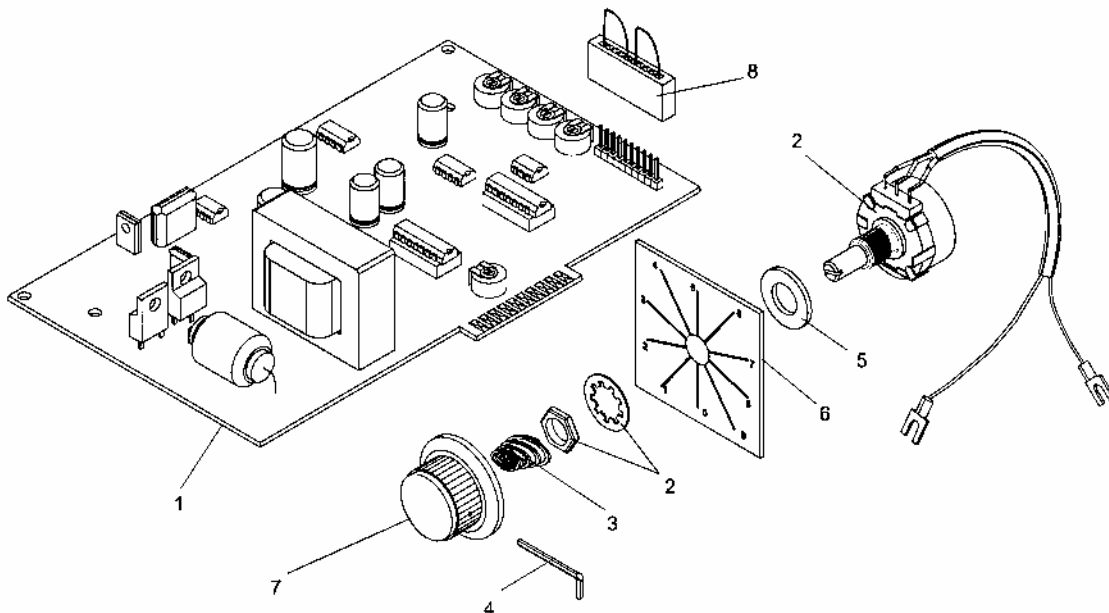

GROUP 17

REPLACEMENT PARTS FOR AUXILIARY INSTALLATION KIT FOR A.B.DICK 385 – 84-160-13

KEY	PART NUMBER	DESCRIPTION	QTY
1.	84-100-82	PAPER BOARD STOP	1
2.	84-101-49	NUT, PRESS SIDE GUIDE STOP	1
3.	84-101-51	BRACKET, PRESS SIDE GUIDE	1
4.	84-140-103	PULSE GENERATOR ASSEMBLY (AB DICK385)	1
5.	123-0113	PLASTIC TIE	4

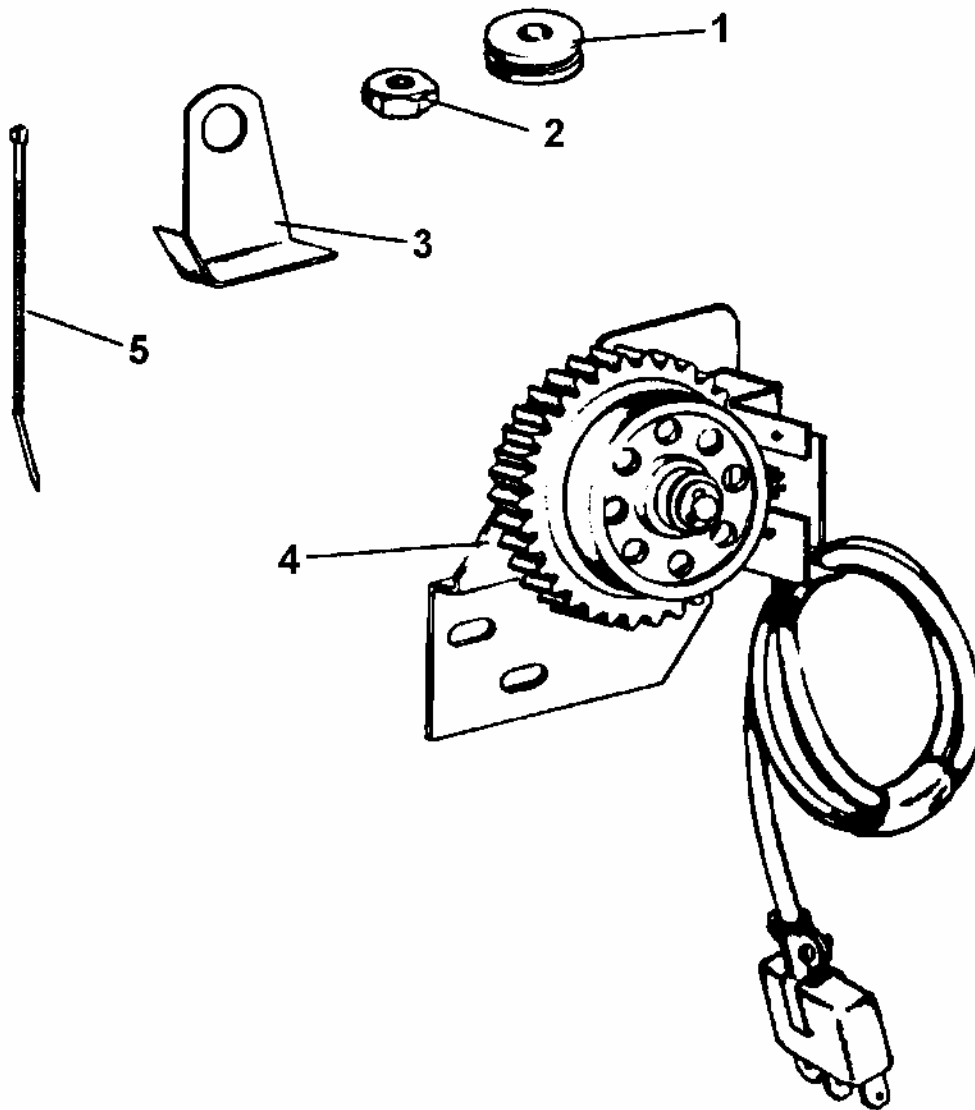

GROUP 18

REPLACEMENT PARTS FOR HAMADA 234 CONVERSION KIT A-224

KEY	PART NUMBER	DESCRIPTION	QTY
1.	89-200-18	FRONT FEED PLATE, WELDMENT	1
2.	87-101-10	PAD, FRONT FEED PLATE	1
3.	123-0446	SCREW, 8-32 X 5/16	3
4.	89-101-14	CLAMP, FRONT FEED PLATE	1
5.	87-101-39	SLEEVE, CLAMP SCREW	1
6.	87-101-16	SCREW ASSEMBLY, CLAMP	1
*7.	123-0113	PLASTIC TIES	4
*8.	84-100-182	PAPER BOARD STOP	1
*9.	89-200-09	PULSE GENERATOR ASSEMBLY.	1
10.	89-200-10	SENSOR BRACKET	1
11.	88-140-13	SENSOR ASSEMBLY	1
12.	123-0612	SCREW, 6-32	2
13.	123-0252	WASHER, STAR #6	2
14.	123-1245	SCREW, 8-31 X 1 ¼	2
15.	123-0262	WASHER, #10	2
16.	89-200-11	BRACKET	1
17.	89-200-12	MAGNET ASSEMBLY	1
18.	123-0709	SET SCREW	1
19.	88-140-77	JUMPER PLUG #2	1

* REPLACEMENT PARTS FOR HAMADA 234 AUXILIARY INSTALLATION KIT A-225

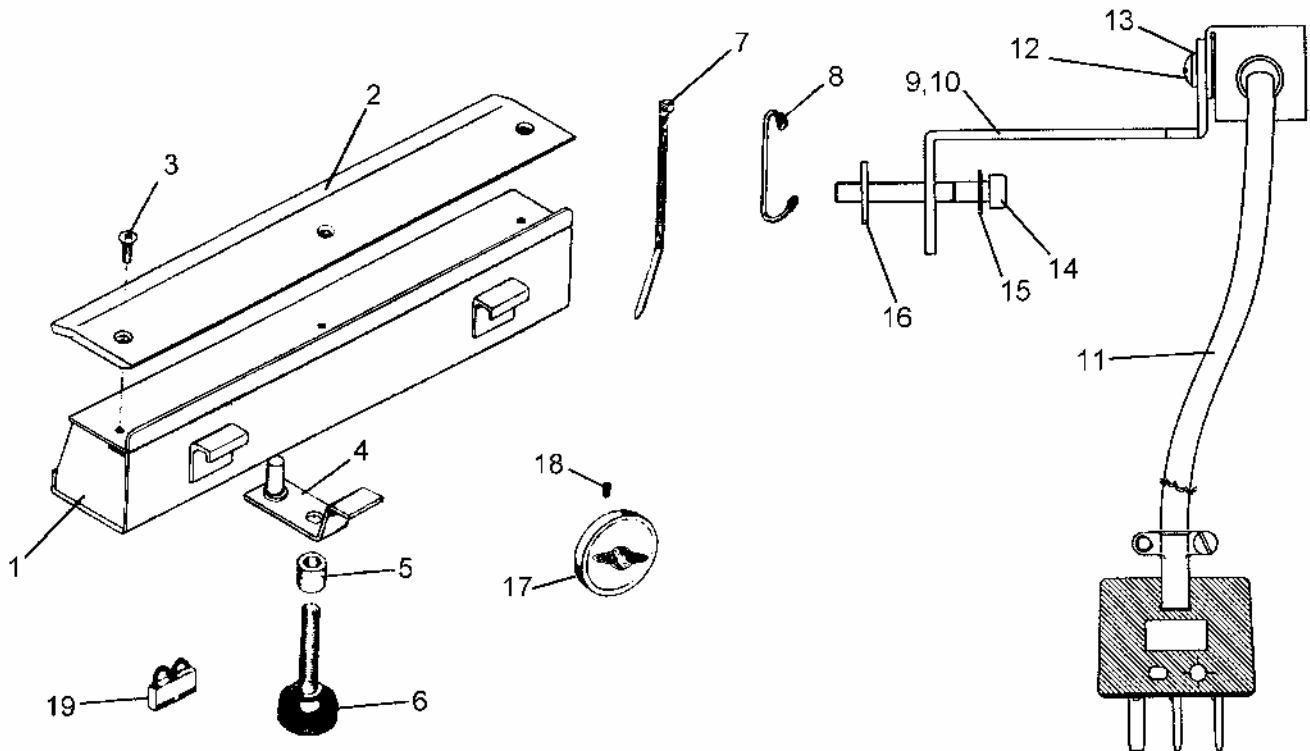

GROUP 19

REPLACEMENT PARTS FOR RYOBI 3302, ITEK 3985 CONVERSION KIT A-218

KEY	PART NUMBER	DESCRIPTION	QTY
1	88-101-15	WELDMENT, FRONT FEED PLATE	1
2	87-101-10	PAD, FRONT FEED PLATE	1
3	123-0446	SCREW	3
4	88-101-14	CLAMP, FRONT FEED PLATE	1
5	87-101-39	SLEEVE, CLAMP SCREW	1
6	87-101-16	SCREW ASSEMBLY, CLAMP	1
*7	123-0113	PLASTIC TIES	4
*8	89-100-82	PAPER BOARD STOP	1
*9	88-140-100	PULSE GENERATOR ASSY.	1
*10	86-103-20	HEIGHT EXTENDER	4
*11	84-140-77	PLUG, JUMPER	1

* REPLACEMENT PARTS FOR RYOBI TO RYOBI 2-COLOR INSTALLATION KIT A-219

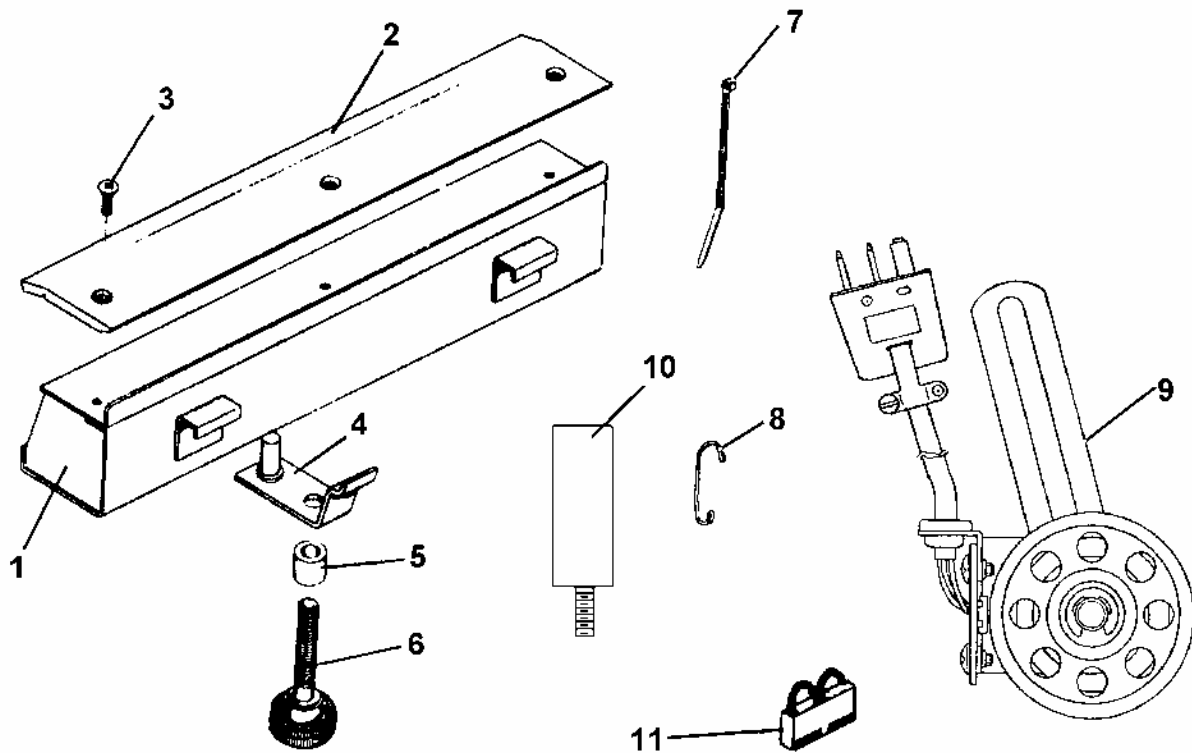

GROUP 20

REPLACEMENT PARTS FOR MULTI 1250, 1300, 1650 CONVERSION KIT A-216

KEY	PART NUMBER	DESCRIPTION	QTY
1.	89-101-15	WELDMENT, FRONT FEED PLATE	1
2.	87-101-10	PAD, FRONT FEED PLATE	1
3.	123-0446	SCREW	3
4.	89-101-14	CLAMP, FRONT FEED PLATE	1
5.	87-101-39	SLEEVE, CLAMP SCREW	1
6.	87-101-16	SCREW ASSEMBLY, CLAMP	1
*7.	123-0113	PLASTIC TIES	4
*8.	89-100-82	PAPER BOARD STOP	1
*9.	89-140-300	PULSE GENERATOR ASSEMBLY	1
10.	89-140-301	SENSOR BRACKET	1
11.	89-140-113	SENSOR ASSEMBLY	1
12.	123-0274	SCREW, 6-32	2
13.	123-0252	WASHER, STAR #6	2
14.	123-0192	NUT, HEX 6-32	2
15.	89-140-107	MAGNET ASSEMBLY	1
16.	123-0311	WASHER, PLASTIC	1
17.	123-0081	TRUARC	1
18.	89-140-77	JUMPER PLUG – MULTI	1

* REPLACEMENT PARTS FOR MULTI 1250, 1300, 1650 AUXILIARY INSTALLATION KIT A-217

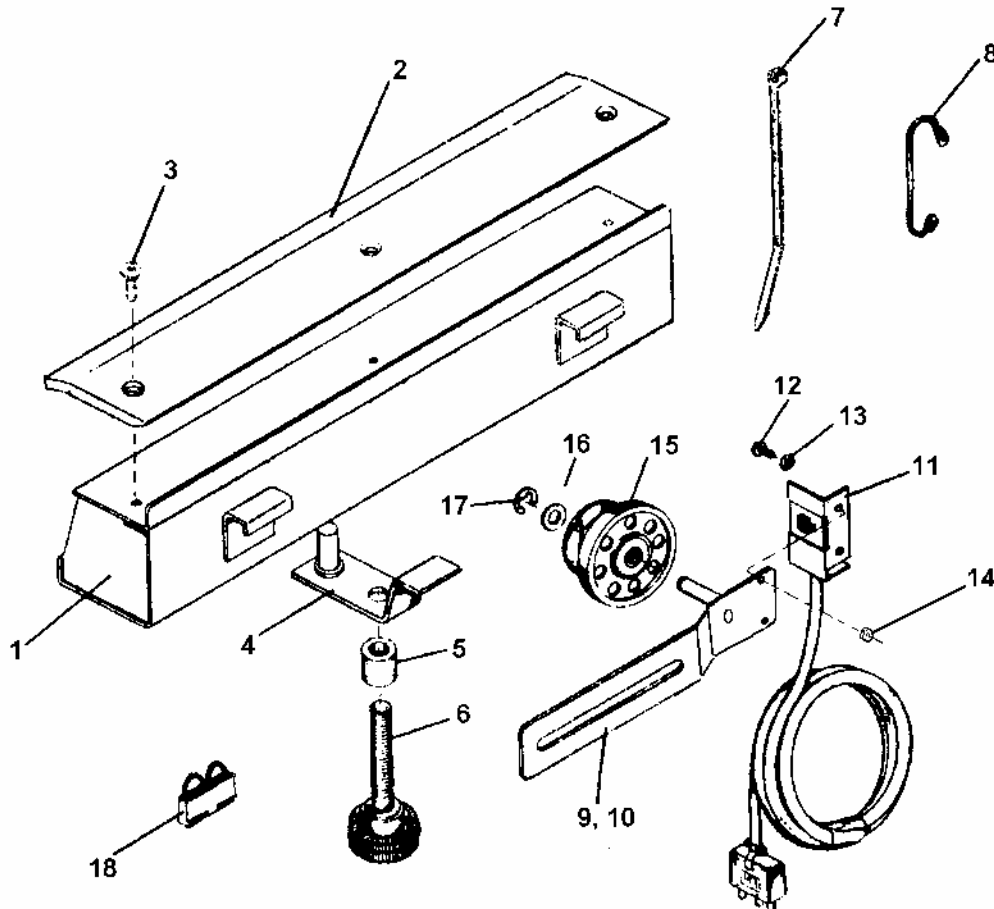

GROUP 21

REPLACEMENT PARTS FOR GESTETNER / CHIEF CONVERSION KIT A-220

KEY	PART NUMBER	DESCRIPTION	QTY
1.	87-101-10	PAD, FRONT FEED PLATE	1
2.	123-0446	SCREW	3
3.	89-101-14	CLAMP, FRONT FEED	1
4.	87-101-39	SLEEVE, CLAMP SCREW	1
5.	87-101-16	SCREW ASSEMBLY CLAMP	1
6.	123-0113	PHOTOTISS	4
*7.	89-100-82	FEED CARD STOP	1
*8.	84-201-17	PULSE GENERATOR ASSEMBLY	1
*9.	89-140-77	SENSOR ASSEMBLY	1
10.	89-140-77	SENSOR ASSEMBLY	1
11.	123-0274	SCREW, 6-32	2
12.	123-0252	WASHER, STAR #6	2
13.	123-0192	NUT, HEX 6-32	2
14.	89-140-77	MAGNET ASSEMBLY	1
15.	123-0001	WASHER, PLASTIC	1
16.	123-0081	TRUARC	1
17.	89-140-77	JUMPER PLUG – GESTETNER	1

OBSOLETE

* REPLACEMENT PARTS FOR GESTETNER / CHIEF AUXILIARY INSTALLATION KIT A-221

NO ILLUSTRATION AVAILABLE

GROUP 22

REPLACEMENT PARTS FOR HEIDELBERG QUICKMASTER

KEY	PART NUMBER	DESCRIPTION	QTY
1.	84-261-106	PAPER RETAINER STRAP ASSEMBLY (HEAVY)	2
2.	84-261-116	PAPER RETAINER STRAP ASSEMBLY (LIGHT)	2
3.	84-130-100	SKID WHEEL ASSEMBLY QM	1
4.	84-130-20	SKID WHEEL ASSEMBLY	1
5.	84-261-38	SIDE GUIDE ASSEMBLY L/H	1
6.	84-261-41	SIDE GUIDE ASSEMBLY R/H	1
7.	84-261-10	PAD, FRONT FEED PLATE	1
8.	84-261-26	FRONT FEED PLATE ASSEMBLY	1
9.	71-125-28	THUMBSCREW	2
10.	84-261-33	GUIDE	2
11.	123-0002	SCREW	4
12.	123-0446	SCREW, 8-32 X 5/16	3
13.	84-261-107	PAPER RETAINER STRAP (HEAVY) QM	2
14.	84-261-117	PAPER RETAINER STRAP (LIGHT) QM	2
	84-261-20	FRAME, CONVEYOR R/H (NOT SHOWN)	1
	84-261-12	FRAME, CONVEYOR L/H (NOT SHOWN)	1

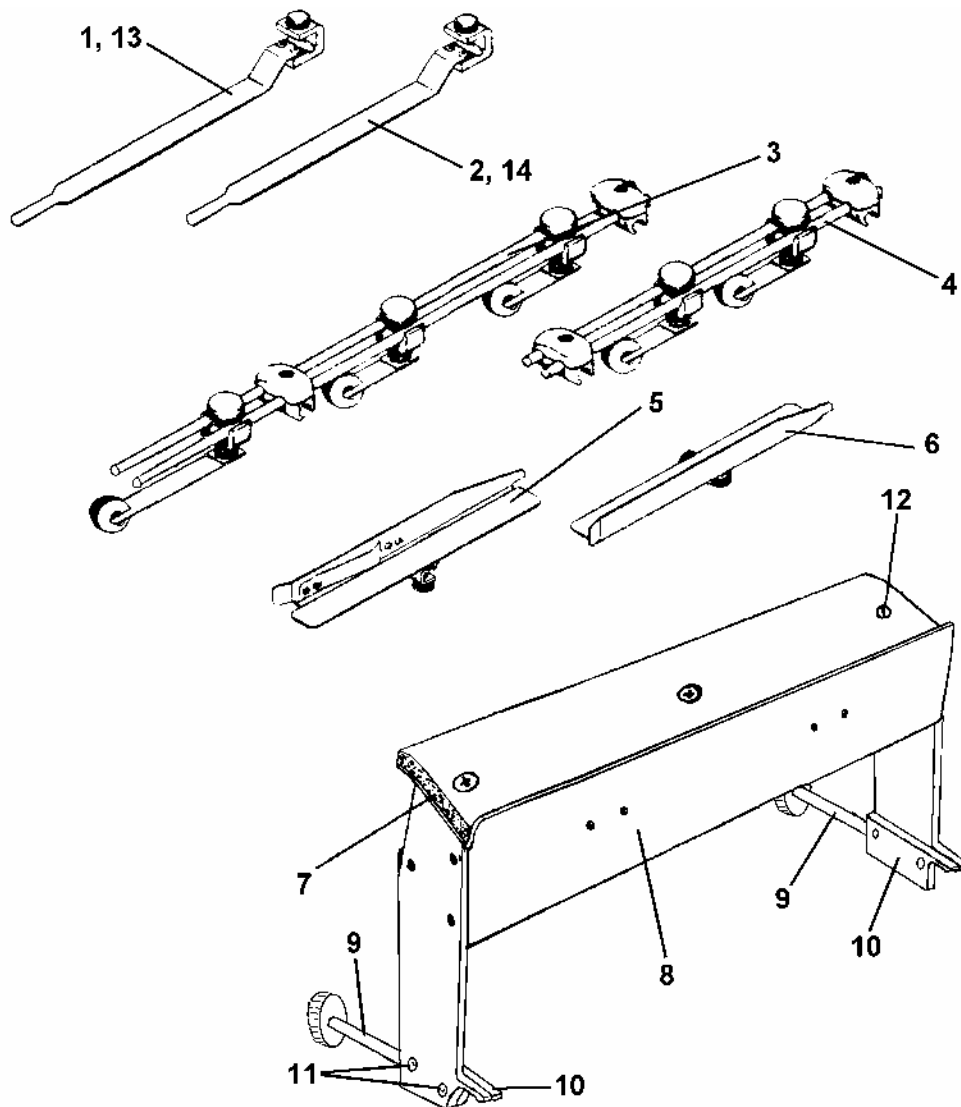

GROUP 23

REPLACEMENT PARTS FOR HAMADA RS34/VS34 CONVERSION KIT A-226

KEY	PART NUMBER	DESCRIPTION	QTY
1.	89-150-19	FRONT FEED PLATE ASSEMBLY	1
2.	87-101-10	PAD, FRONT FEED PLATE	1
3.	123-0446	SCREW	3
4.	89-101-14	CLAMP, FRONT FEED PLATE	1
5.	87-101-39	SLEEVE, CLAMP SCREW	1
6.	87-101-16	SCREW ASSEMBLY, CLAMP	1
*7.	123-0113	PLASTIC TIES	4
*8.	89-100-82	PAPER BOARD STOP	1
*9.	89-150-200	PULSE GENERATOR ASSEMBLY	1
10.	89-150-201	SENSOR BRACKET	1
11.	89-140-213	SENSOR ASSEMBLY	1
12.	123-0274	SCREW, 6-32	2
13.	123-0252	WASHER, STAR #6	2
14.	89-140-207	MAGNET ASSEMBLY	1
15.	123-0311	WASHER, PLASTIC	1
16.	123-0081	TRUARC	1
17.	89-140-77	JUMPER PLUG – HAMADA	1

* REPLACEMENT PARTS FOR HAMADA RS34/VS34 AUXILIARY INSTALLATION KIT A-227

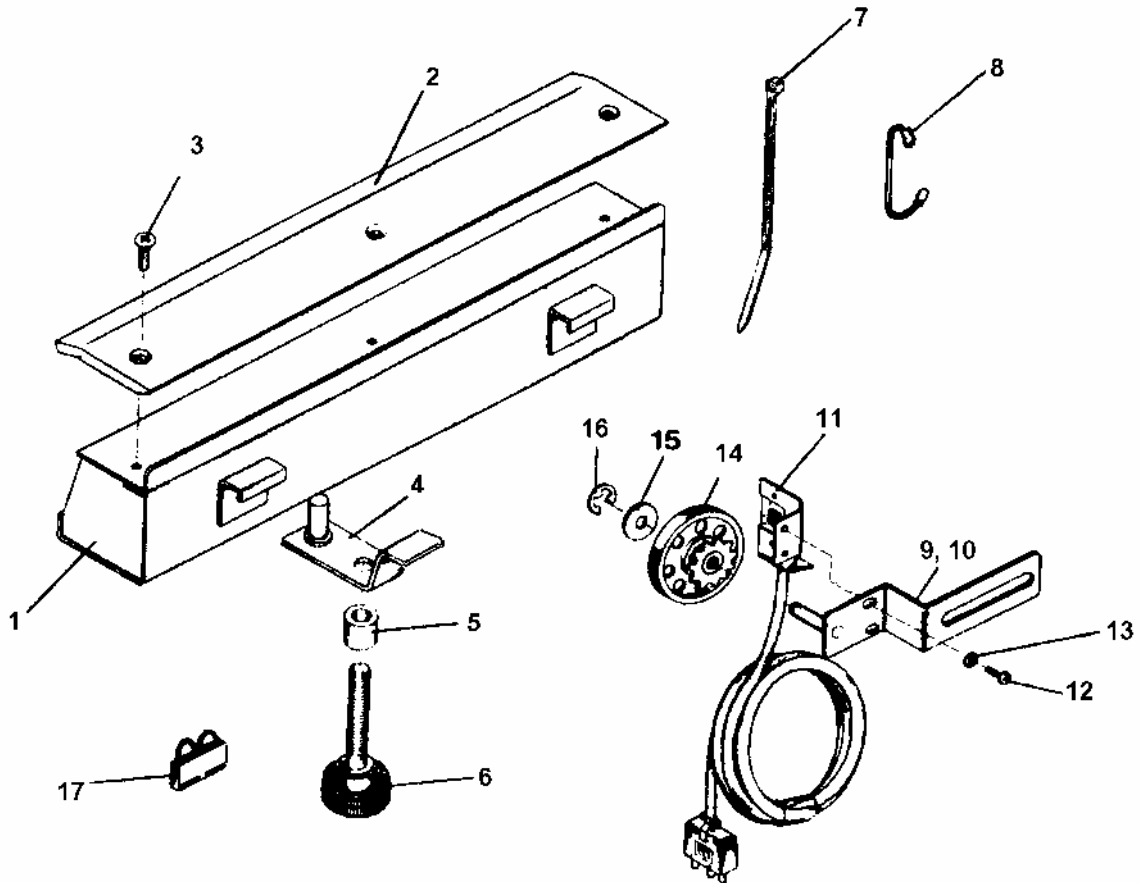

GROUP 24

REPLACEMENT PARTS FOR HEIDELBERG PRINTMASTER

KEY	PART NUMBER	DESCRIPTION	QTY
1.	84-262-106	PAPER RETAINER STRAP ASSEMBLY (HEAVY)	2
2.	84-262-116	PAPER RETAINER STRAP ASSEMBLY (LIGHT)	2
3.	86-125-46	SKID ROLLER ASSEMBLY (LONG)	2
4.	71-130-02	SKID WHEEL ASSEMBLY	2
5.	84-261-38	SIDE GUIDE ASSEMBLY L/H	1
6.	84-261-41	SIDE GUIDE ASSEMBLY R/H	1
7.	84-261-10	PAD, FRONT FEED PLATE	1
8.	84-262-26	FRONT FEED PLATE ASSEMBLY	1
9.	84-262-08	THUMBSCREW	2
10.	84-262-11	INSERT	2
11.	123-0446	SCREW, 8-32 X 5/16	3
12.	84-261-107	PAPER RETAINER STRAP (HEAVY) QM	2
13.	84-261-117	PAPER RETAINER STRAP (LIGHT) QM	2
	84-261-20	FRAME, CONVEYOR R/H (NOT SHOWN)	1
	84-261-12	FRAME, CONVEYOR L/H (NOT SHOWN)	1

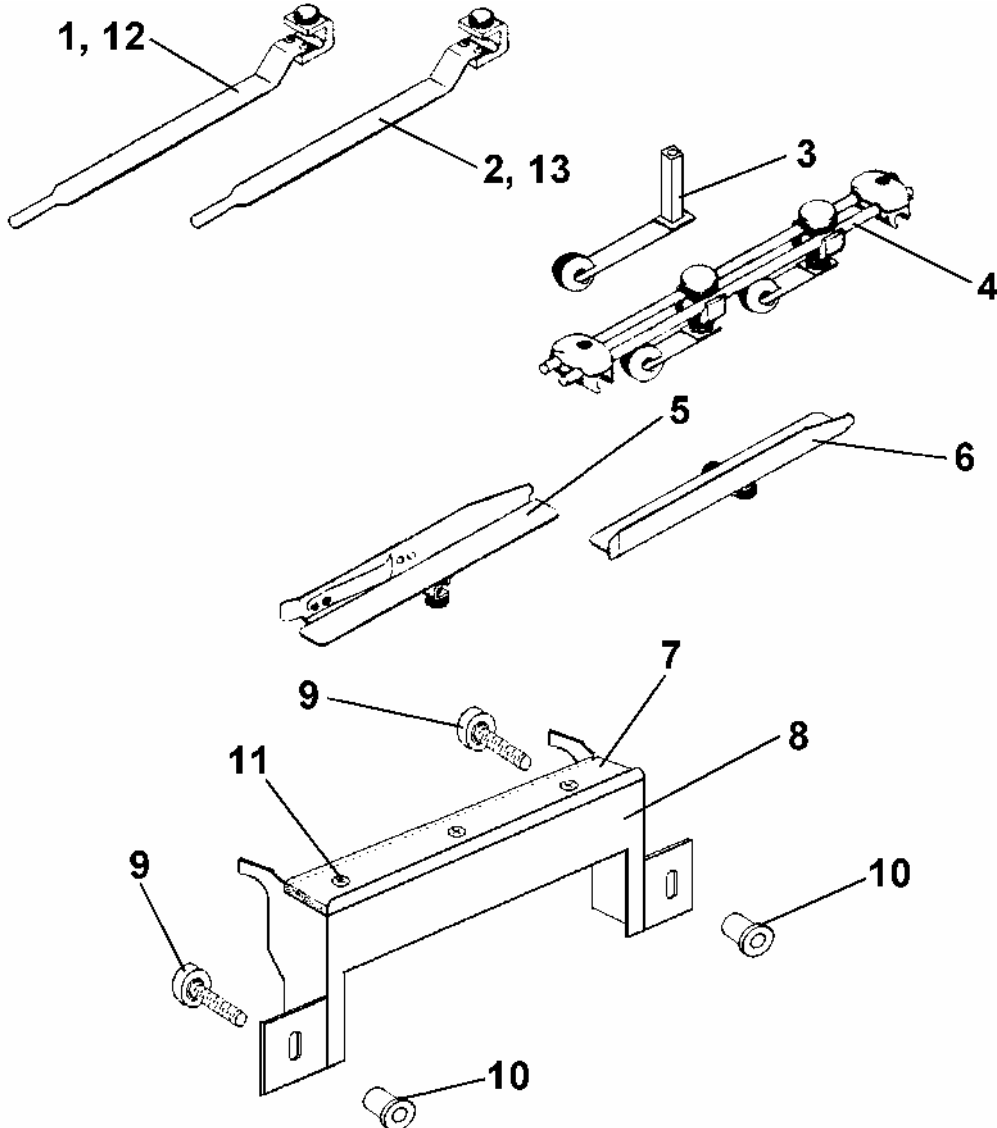

GROUP 25

REPLACEMENT PARTS FOR AB DICK 9920 CONVERSION KIT A-220

KEY	PART NUMBER	DESCRIPTION	QTY
1.	88-101-15	WELDMENT, FRONT FEED PLATE	1
2.	87-101-10	PAD, FRONT FEED PLATE	1
3.	123-0446	SCREW	3
4.	88-101-14	CLAMP, FRONT FEED PLATE	1
5.	87-101-39	SLEEVE, CLAMP SCREW	1
6.	87-101-16	SCREW ASSEMBLY, CLAMP	1
*7.	123-0113	PLASTIC TIES	4
*8.	88-100-82	PAPER BOARD STOP	1
*9.	89-250-02	PULSE GENERATOR ASSEMBLY	1
10.	89-140-77	JUMPER PLUG	1

* REPLACEMENT PARTS FOR RYOBI AUXILIARY INSTALLATION KIT A-221

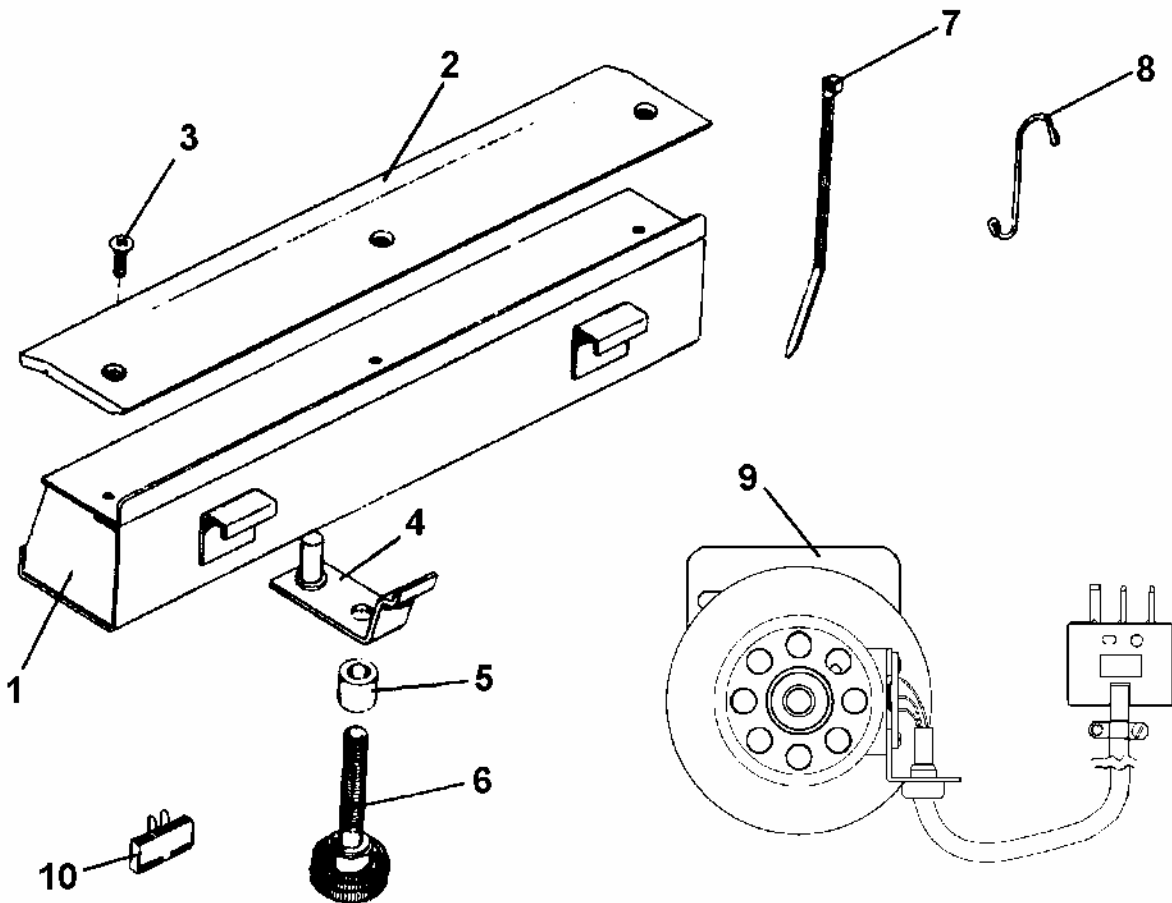

NORMAL WEAR PARTS – AMC-2000

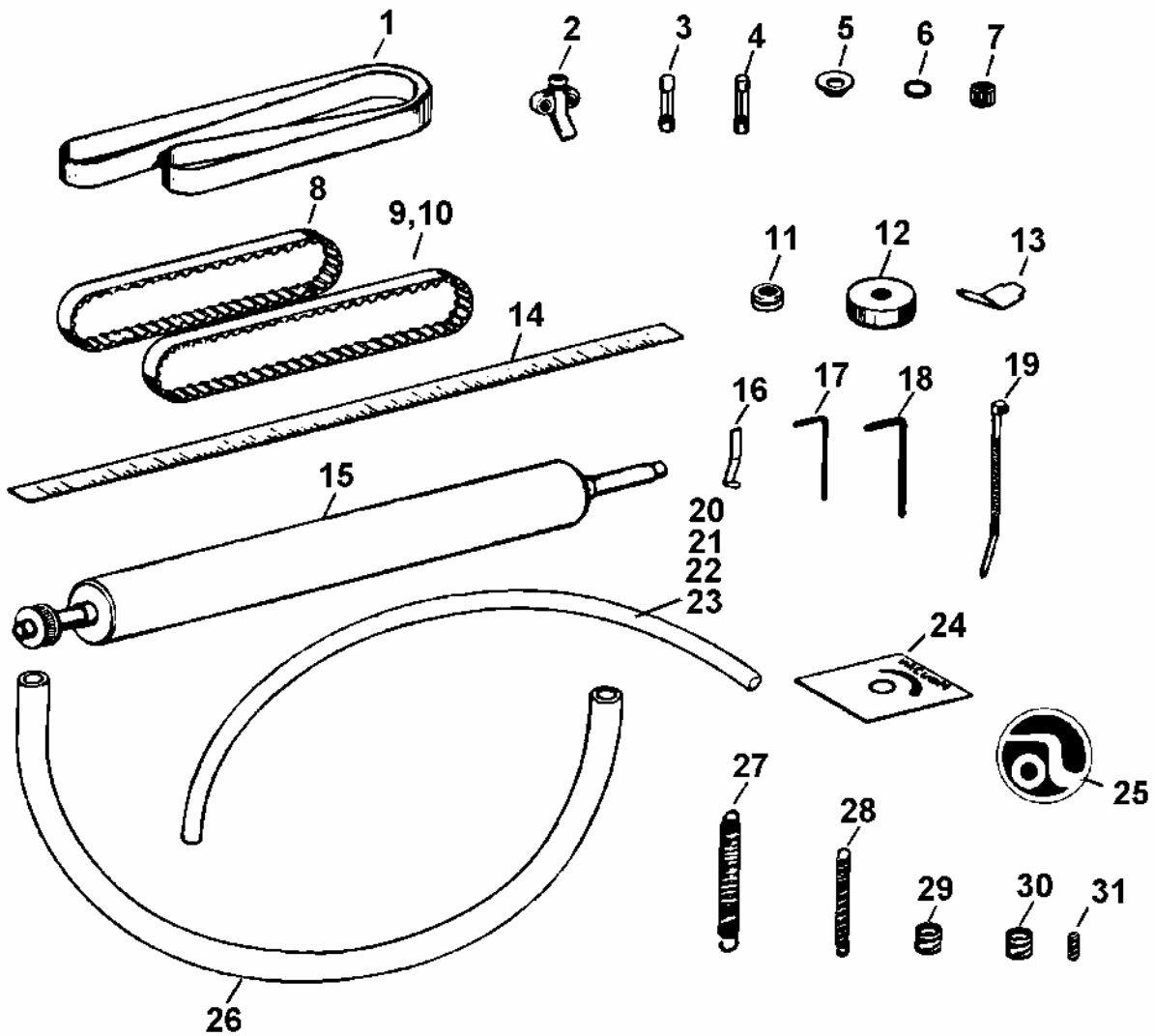

KEY # PART # DESCRIPTION

1	123-0107	CONVEYOR BELT
2	84-105-22	FITTING, SUCTION CUP
3	123-0285	FUSE, 2 AMP FAST BLOW
4	123-0090	FUSE, 10 AMP SLO BLOW
5	71-134-15	SUCTION CUP
6	123-0472	O-RING
7	123-0415	CAP, SUCTION FOOT
8	123-0338	TIMING BELT, 100XL031
9	123-0140	TIMING BELT, 110XL037
10	123-0277	TIMING BELT 110XL031
11	123-0092	GROMMET
12	123-0208	RUBBER PAD
13	71-130-15	SPRING, TAPE GUIDE
14	123-0328	SCALE GUIDE
15	84-115-20	RUBBER ROLLER ASSEMBLY
16	71-109-05	SHEET SEPARATOR (STANDARD)

KEY # PART # DESCRIPTION

16	71-109-05B	SHEET SEPARATOR (HEAVY)
17	123-0057	ALLEN WRENCH, 1/16
18	123-0058	ALLEN WRENCH, 3/32
19	123-0113	PLASTIC TIE
20	84-106-40A	HOSE VACUUM 10-1/4"
21	84-106-40B	HOSE VACUUM 13-1/4"
22	84-106-40C	HOSE VACUUM 15-1/2"
23	84-106-40D	HOSE VACUUM 16-3/4"
24	123-0407	DECAL, VACUUM VALVE
25	123-0752	DECAL, ASTRO LOGO
26	84-106-41	HOSE, VACUUM PUMP
27	84-120-10	SPRING, U.P.O.R.
28	80-120-25	SPRING, JOGGER GUIDE
29	84-120-31	SPRING, VALVE NEEDLE
30	84-120-05	SPRING, SIDE GUIDE
31	71-120-09	SPRING, CARRIAGE TILT

Numerical Index

PART #	KEY #	GROUP	PART #	KEY #	GROUP	PART #	KEY #	GROUP
123-0001	79	4	123-0107	29	3	123-0252	13	12
123-0002	11	22	123-0113	19	9	123-0252	13	13
123-0002	24	4	123-0113	5	17	123-0252	13	14
123-0003	27	4	123-0113	6	21	123-0252	13	15
123-0008	41	4	123-0113	7	11	123-0252	13	18
123-0010	33	1	123-0113	7	12	123-0252	13	20
123-0017	2	2	123-0113	7	13	123-0252	13	23
123-0017	7	4	123-0113	7	14	123-0252	95	4
123-0017	59	3	123-0113	7	15	123-0256	15	14
123-0018	12	2	123-0113	7	18	123-0256	15	15
123-0024	1	6	123-0113	7	19	123-0257	72	3
123-0024	4	4	123-0113	7	20	123-0262	15	18
123-0024	24	3	123-0113	7	23	123-0262	51	2
123-0024	49	2	123-0113	7	25	123-0263	84	4
123-0034	47	2	123-0113	16	6	123-0274	3	8
123-0035	35	4	123-0113	16	10	123-0274	8	4
123-0036	21	4	123-0114	21	5	123-0274	11	21
123-0050	17	3	123-0125	1	3	123-0274	12	11
123-0050	47	4	123-0125	2	5	123-0274	12	12
123-0050	48	2	123-0126	32	1	123-0274	12	13
123-0051	37	2	123-0127	41	1	123-0274	12	14
123-0054	6	1A	123-0127	50	3	123-0274	12	15
123-0054	30	2	123-0131	35	2	123-0274	12	20
123-0054	73	4	123-0135	16	2	123-0274	12	23
123-0057	4	16	123-0140	61	4	123-0275	29	4
123-0063	7	1A	123-0143	27	2	123-0275	39	3
123-0063	8	8	123-0143	31	4	123-0276	21	3
123-0063	28	2	123-0145	53	2	123-0277	23	4
123-0064	29	2	123-0180	44	1	123-0280	15	10
123-0064	30	4	123-0182	75	4	123-0280	23	3
123-0073	7	1	123-0185	1	7	123-0280	94	4
123-0076	6	8	123-0185	48	3	123-0285	12	5
123-0077	83	4	123-0192	13	21	123-0293	23	2
123-0080	10	4	123-0192	14	20	123-0299	5	5
123-0080	32	3	123-0192	38	3	123-0305	6	16
123-0081	7	8	123-0194	13	8	123-0311	11	8
123-0081	15	12	123-0195		8	123-0311	13	1A
123-0081	16	11	123-0196	91	4	123-0311	15	11
123-0081	16	13	123-0199	77	4	123-0311	15	13
123-0081	16	21	123-0200	19	2	123-0311	15	21
123-0081	16	23	123-0200	76	4	123-0311	15	23
123-0081	17	20	123-0208	1	1A	123-0311	16	20
123-0081	43	4	123-0229	4	5	123-0311	45	2
123-0082C	80	4	123-0236R		4	123-0312	52	2
123-0090	13	5	123-0237	2	7	123-0328	42	1
123-0092	15	6	123-0237	50	2	123-0338	56	4
123-0093	10	1A	123-0237	70	4	123-0339	45	3
123-0096	5	16	123-0240	70	3	123-0340	8	1A
123-0096	44	2	123-0241	13	3	123-0345	14	3
123-0099	58	3	123-0241	16	5	123-0350	93	4
123-0100	33	3	123-0252	12	21	123-0351	10	5
123-0102	22	4	123-0252	13	11	123-0352	6	5

PART #	KEY #	GROUP	PART #	KEY #	GROUP	PART #	KEY #	GROUP
123-0353	8	5	123-0707	25	2	71-125-46	9	3
123-0354	7	5	123-0709	18	18	71-125-47E	12	3
123-0355	11	5	123-0752	11	1	71-125-48	10	3
123-0358	37	3	123-0757	38	2	71-125-84	16	3
123-0371	45	4	123-0841	9	2	71-130-13	26	3
123-0374	52	4	123-0855	39	2	71-130-15	27	3
123-0375	38	4	123-0975	31	1	71-134-15	1	4
123-0377	14	5	123-1245	14	18	71-140-08	1	10
123-0387	68	4	123-1626	3	7	71-140-08	2	1
123-0390	2	6	123-1936	54	2	71-140-08L	2	1
123-0390	7	16	156-102-18	1	2	71-140-10	2	10
123-0390	9	5	156-103-03	22	2	71-140-10	3	1
123-0394	3	1A	156-103-04	26	2	71-140-10L	3	1
123-0394	92	4	156-103-05	3	2	71-140-13	3	10
123-0398	57	4	156-103-06	5	2	71-140-13	27	1
123-0399	32	4	156-103-07	4	2	74-100-13	23	1
123-0401	4	6	156-103-08	13	2	74-105-12	11	4
123-0407	26	1	156-103-09	14	2	80-100-34	74	4
123-0408	17	5	156-103-11	11	2	80-108-20	2	1A
123-0415	65	4	156-103-12	10	2	80-108-22	4	1A
123-0423	14	4	156-103-20	17	2	80-112-03A	43	3
123-0426	13	10	156-103-21	15	2	80-112-04	46	3
123-0426	19	5	156-103-23	20	2	80-112-06	34	3
123-0431	68	3	156-103-25	6	2	80-112-21	44	3
123-0433	20	1	156-103-26	18	2	80-120-24	3	16
123-0436	16	1A	156-103-27	8	2	80-120-25	36	3
123-0436	41	2	56-108-22	43	2	84-100-001	3	5
123-0446	2	21	56-114-03	7	10	84-100-002	3	5
123-0446	3	11	56-114-03	18	1	84-100-003	3	5
123-0446	3	12	56-114-03	53	3	84-100-004	3	5
123-0446	3	13	56-114-04	8	10	84-100-005	3	5
123-0446	3	14	56-114-04	17	1	84-100-006	3	5
123-0446	3	15	56-114-06	6	3	84-100-008	3	5
123-0446	3	18	56-114-12	52	3	84-100-012	3	5
123-0446	3	19	56-114-17	55	3	84-100-014	3	5
123-0446	3	20	71-108-04A	36	1	84-100-015	3	5
123-0446	3	23	71-108-06A	35	1	84-100-016	3	5
123-0446	11	3	71-108-09	30	1	84-100-017	3	5
123-0446	12	22	71-108-15	28	1	84-100-018	3	5
123-0446	11	24	71-109-03A	37	1	84-100-100	3	5
123-0446	3	25	71-109-05	34	1	84-100-00A	1	16
123-0450	6	5	71-109-07	3	3	84-100-01B	62	4
123-0460	22	1	71-109-07	40	1	84-100-02B	26	4
123-0462	21	1	71-109-07	49	3	84-100-15	11	10
123-0471	72	4	71-109-11	29	1	84-100-15	19	1
123-0472	14	10	71-120-01	66	4	84-100-182	8	18
123-0472	65	3	71-120-06	8	3	84-100-20	15	1
123-0497	85	4	71-120-09	12	4	84-100-22B	9	1
123-0517	31	2	71-121-03	15	4	84-100-54	48	4
123-0521	32	2	71-121-05	33	4	84-100-56B	1	1
123-0523	47	3	71-121-06	40	4	84-100-62	81	4
123-0527	8	6	71-125-17	7	3	84-100-74B	14	1
123-0612	12	18	71-125-21	4	3	84-100-75B	12	1
123-0695	7	2	71-125-28	9	22	84-100-81	13	1
123-0701	46	2	71-125-37A	15	3	84-100-82	1	8

PART #	KEY #	GROUP	PART #	KEY #	GROUP	PART #	KEY #	GROUP
84-100-82	1	9	84-106-11	67	4	84-130-20	4	24
84-100-82	1	17	84-106-19	63	4	84-140-00	4	12
84-101-02	62	3	84-106-20	64	4	84-140-00	12	8
84-101-02W	69	3	84-106-28	10	6	84-140-01	2	8
84-101-07	19	3	84-106-28	25	4	84-140-07	5	8
84-101-10	61	3	84-106-40A	11	6	84-140-103	4	17
84-101-10W	66	3	84-106-40B	12	6	84-140-12	12	10
84-101-12	41	3	84-106-40C	13	6	84-140-13	4	8
84-101-14	64	3	84-106-40D	14	6	84-140-20	9	10
84-101-15	60	3	84-106-41	36	2	84-140-22	17	10
84-101-15W	67	3	84-107-06	34	4	84-140-22	71	3
84-101-16	63	3	84-107-08	36	4	84-140-66	1	5
84-101-17	18	3	84-107-09	51	4	84-140-70	15	5
84-101-17	50	4	84-107-12	46	4	84-140-70P	20	5
84-101-18	96	4	84-107-13	44	4	84-140-71	22	3
84-101-19	31	3	84-107-14	42	4	84-140-71	86	4
84-101-20B	20	3	84-108-02	8	1	84-140-72	90	4
84-101-24	28	3	84-108-03	10	1	84-140-73	87	4
84-101-25	35	3	84-108-20	4	10	84-140-74	88	4
84-101-26	30	3	84-108-20	43	1	84-140-75	89	4
84-101-27	40	3	84-108-20L	43	1	84-140-77	8	16
84-101-29	25	3	84-108-22	5	1	84-140-77	11	19
84-101-31	5	3	84-108-23	6	1	84-140-77	18	5
84-101-41	55	4	84-108-25	4	1	84-140-78	15	1A
84-101-45	59	4	84-114-05	57	3	84-140-78	40	2
84-101-46	58	4	84-114-12	51	3	84-140-84	2	16
84-101-49	10	9	84-114-34	45	1	84-150-25	56	3
84-101-49	2	17	84-115-20	19	4	84-160-10		16
84-101-49	10	8	84-117-11	20	4	84-160-11		16
84-101-51	9	9	84-120-05	54	3	84-160-12		16
84-101-51	3	17	84-120-10	6	4	84-201-17	8	21
84-101-51	9	8	84-120-10	49	4	84-261-10	7	22
84-102-10	37	4	84-120-26A	39	4	84-261-10	7	24
84-103-01	5	1A	84-120-26B	39	4	84-261-106	1	22
84-103-05	9	1A	84-120-31	3	6	84-261-107	13	22
84-103-07	11	1A	84-121-12	28	4	84-261-116	2	22
84-103-07	34	2	84-121-12	42	3	84-261-117	14	22
84-103-08	12	1A	84-121-18	54	4	84-261-12		22
84-103-10	14	1A	84-122-22	78	4	84-261-12		24
84-103-10	42	2	84-122-25	60	4	84-261-20		22
84-104-00	53	4	84-125-107	2	3	84-261-20		24
84-104-06	69	4	84-125-108	6	10	84-261-26	8	22
84-104-07	82	4	84-125-108	24	1	84-261-33	10	22
84-105-01	16	4	84-125-110	10	10	84-261-38	5	22
84-105-08	9	4	84-125-110	16	1	84-261-38	5	24
84-105-12	11	4	84-125-111	38	1	84-261-41	6	22
84-105-22	2	4	84-125-112	39	1	84-261-41	6	24
84-105-30	5	4	84-128-08	4	7	84-262-08	9	24
84-105-31	18	4	84-128-08	71	4	84-262-11	10	24
84-105-35	3	4	84-128-80	5	7	84-262-26	8	24
84-105-36	13	4	84-130-100	3	22	84-262-106	1	24
84-105-37	17	4	84-130-100	3	24	84-262-107	12	24
84-106-03	5	6	84-130-20	4	22	84-262-116	2	24
84-106-07	6	6	84-130-20	5	10	84-262-117	13	24
84-106-08	7	6	84-130-20	25	1	86-103-04	21	2

PART #	KEY #	GROUP	PART #	KEY #	GROUP	PART #	KEY #	GROUP
86-103-06	24	2	88-140-02	10	14	89-150-200	9	23
86-103-20	10	19	88-140-07	14	14	89-150-201	10	23
86-103-31	33	2	88-140-08	9	14	89-200-09	9	18
86-106-41	9	6	88-140-100	9	19	89-200-10	10	18
86-125-46	7	3	88-140-13	11	14	89-200-11	16	18
86-125-46	24	3	88-140-13	11	18	89-200-12	17	18
87-101-10	1	21	88-140-77	16	14	89-200-18	1	18
87-101-10	2	11	88-140-77	16	15	89-250-02	9	25
87-101-10	2	12	88-140-77	19	18	AK524		2
87-101-10	2	13	89-100-82	7	21	K247		2
87-101-10	2	14	89-100-82	8	11	K478		2
87-101-10	2	15	89-100-82	8	12			
87-101-10	2	18	89-100-82	8	13			
87-101-10	2	19	89-100-82	8	15			
87-101-10	2	20	89-100-82	8	19			
87-101-10	2	23	89-100-82	8	20			
87-101-10	2	25	89-100-82	8	23			
87-101-14	4	15	89-101-14	3	21			
87-101-15	1	15	89-101-14	4	11			
87-101-16	5	21	89-101-14	4	12			
87-101-16	6	11	89-101-14	4	13			
87-101-16	6	12	89-101-14	4	18			
87-101-16	6	13	89-101-14	4	20			
87-101-16	6	14	89-101-14	4	23			
87-101-16	6	15	89-101-15	1	11			
85-101-16	6	18	89-101-15	1	12			
87-101-16	6	19	89-101-15	1	13			
87-101-16	6	20	89-101-15	1	20			
87-101-16	6	23	89-140-00	9	12			
87-101-16	6	25	89-140-01	10	12			
87-101-39	4	21	89-140-07	14	12			
87-101-39	5	11	89-140-100	9	11			
87-101-39	5	12	89-140-101	9	21			
87-101-39	5	13	89-140-101	10	11			
87-101-39	5	14	89-140-107	14	11			
87-101-39	5	15	89-140-107	14	21			
87-101-39	5	18	89-140-107	15	20			
87-101-39	5	19	89-140-107	15	20			
87-101-39	5	19	89-140-113	10	21			
87-101-39	5	20	89-140-113	11	11			
87-101-39	5	23	89-140-113	11	20			
87-101-39	5	25	89-140-13	11	12			
87-140-02	10	15	89-140-200	9	13			
87-140-07	14	15	89-140-201	10	13			
87-140-08	9	15	89-140-207	14	13			
87-140-13	11	15	89-140-207	14	23			
87-140-77	16	12	89-140-213	11	13			
87-140-77	17	13	89-140-213	11	23			
88-100-82	8	14	89-140-300	9	20			
88-100-82	8	25	89-140-301	10	20			
88-101-14	4	14	89-140-77	17	11			
88-101-14	4	19	89-140-77	17	21			
88-101-14	4	25	89-140-77	17	23			
88-101-15	1	14	89-140-77	18	20			
88-101-15	1	19	89-140-77	10	25			
88-101-15	1	25	89-150-19	1	23			



Copyright © 2006 Astro Machine Corporation
Elk Grove Village, Illinois 60007
08/31/2006

P/N: 100-AMC2000 Rev .H.