

959 SCHEMATIC

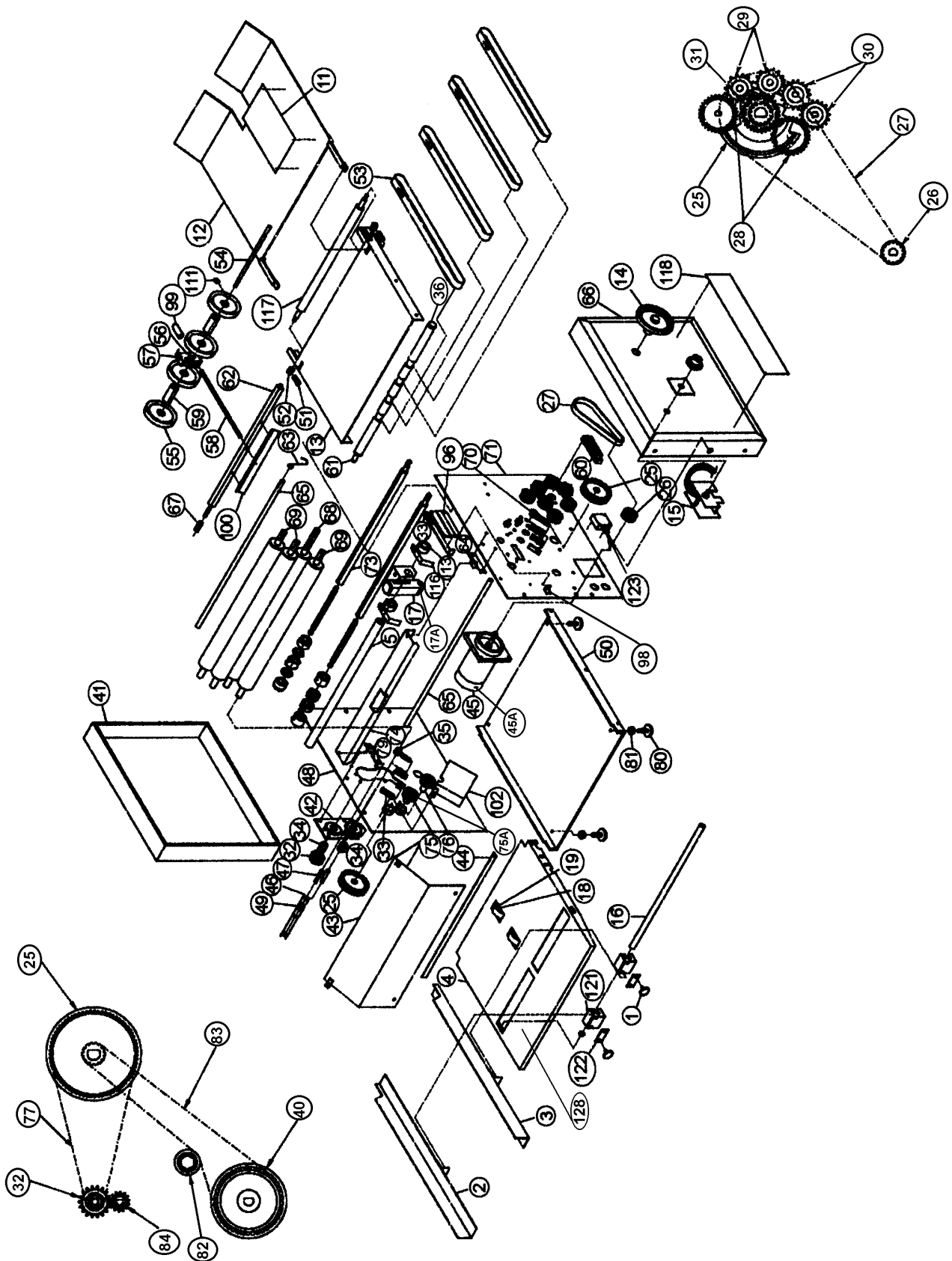

959 PARTS LIST

<u>Item #</u>	<u>Description</u>	<u>Qty.</u>	<u>Part number</u>
1	Paper Guide Adjustment Knob	2	W-O032036
2	Paper Guide (LS)	1	W-A095040
3	Paper Guide (RS)	1	W-A095041
4	Feed Table Only	1	W-A095285
5	¾" Tie Rod	1	M-O003066
6	¼-20X5/8 Thumb Knob	2	W-O032036
7	Upper Fold Indicator Ruler	1	M-S015283
8	Paper Stop	2	W-O095012
8A	Paper Stop Rubber Button	14	M-S030015
9	Fold Table Assembly	2	WRA095101
10	Micro Adjustment Wheel	2	M-O095131
11	Folding Chart	1	MRO003108
12	Receiving Tray	1	W-A095064
13	Exit Table	1	W-O095035
14	Handwheel W/ Setscrew	1	M-S032047
15	Variable Speed Control	1	WRA095500
16	Paper Guide Rod	1	M-O095015
17	Retarder Housing	1	W-A095119
17A	Retarder	1	WRA003116
18	Feed Roll Arbor Assembly	2	W-I095143
19	Feed Roll Tire	2	W-O008015
20	Aluminum Deflector	2	W-O095124
21	Adjusting Screw	4	M-O095260
22	Spacer	2	M-O095037
23	Tie Bar	2	W-O095032
25	60T/15T Timing Pulley	2	M-S022021
26	Motor Pulley	1	M-S022017
27	210T Timing Belt	1	M-S025010
28	24T 3/8I.D. Gear	2	M-O003033
29	18T 1/4I.D. Gear	2	M-O003036
30	18T 3/8I.D. Gear	2	M-O003035
31	24T 1/2I.D. Gear	1	M-O03034A
32	Dual Gear	1	W-O095136
33	Compression Spring	4	M-S031059
34	Bushing	6	M-S013009
35	Bushing	1	W-S013008
36	Nyliner	2	M-S014021
37	Accessory Shaft Journal	2	W-O003019
38	10-32X1 ¼ S.H.C.S.	1	M-S003032
39	Bushing Retainer	1	M-O095204
40	44T Timing Pulley w/ Flange	1	W-S022019

Quick Reference Part Number List

Rollers And Bushings

Bushing part numbers are provided here for easy identification. Rollers are counted from top to bottom.

Roller #	Description	Roller Part #	Left Bushing Part #	Right Bushing Part #
1	Top Fixed Folding Roller	WRA003015	M-S013009	M-S013010
2	Floating Folding Roller*	WRA003015	M-S013009	M-S013009
3	Main Drive Roller	WRA095034	M-S013009	M-S013013
4	Bottom Floating Roller*	WRA003015	M-S013009	M-S013009

*Note: Each floating roller uses 2 springs, part number M-S031059.

Additional often requested part numbers.

Feed Roller Rubber (Red)	W-O008015
Retarder Rubber Roller w/Arbor	WRA003116
Roller Cleaner and Rejuvenator	200
Static Spray	300
Rubber Guide Roller on Accessory Shaft	M-O003080
Speed Control	WRA095500
Circuit Breaker	M-S045194
3 Tooth Perf	WRA03085C
14 Tooth Perf	WRA03085D

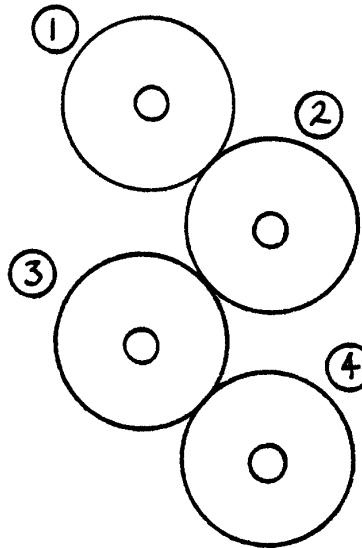

1. Roller = WRA003015
 Roller bearings = 1 M-S013009 (Non-operator side)
 1 M-S013010 (Operator side)
2. Roller = WRA003015
 Roller bearings = 2 M-S013009
 Roller springs = 2 M-S031059
3. Roller = WRA095034
 Roller bearings = M-S013009 (Non-operator side)
 M-S013013 (Operator side)
4. Roller = WRA003015
 Roller bearings = 2 M-S013009
 Roller springs = 2 M-S031059

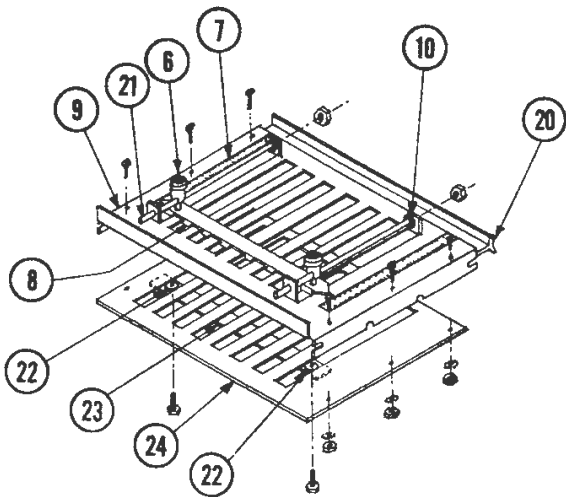

Assembly 251X, Upper and Lower Fold Tables Complete - WRA095101

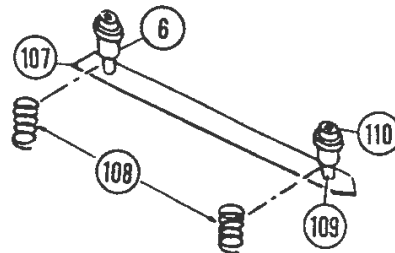

Assembly 252X, Fold Adjustment Assembly WRA095102

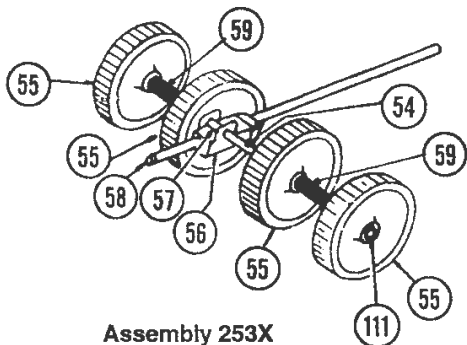

Assembly 253X Stacking Wheel Assembly WRA095103

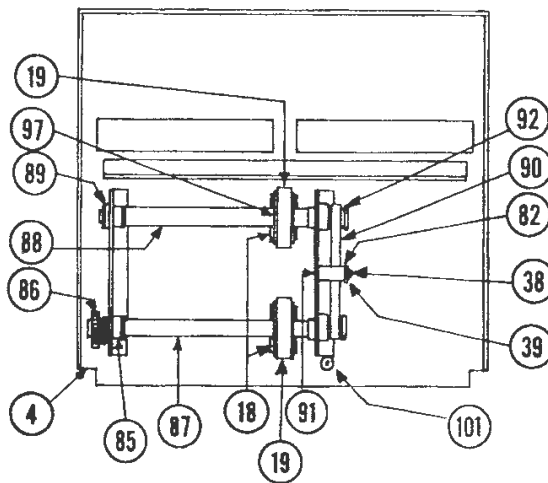

Feed Table 354X Parts Detail

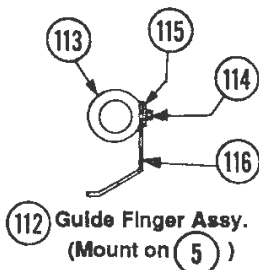

112 Guide Finger Assy. (Mount on 5)

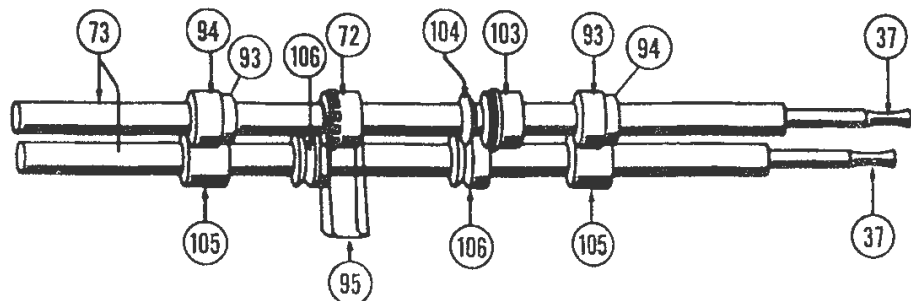

Upper and Lower Accessory Shafts

<u>Item #</u>	<u>Description</u>	<u>Qty.</u>	<u>Part number</u>
41	Left Side Cover	1	M-O095902
42	Bearing Plate	1	W-O095275
43	Motor Shield Assembly	1	W-A095273
44	Base Stiffener	1	W-O095274
45	Motor 120V (Serial above 4,000)	1	M-S021048
45A	Motor Brushes (Leeson)	2	MRS045138
46	Feed Support Plate	1	W-O095286
47	Feed Support Spacer	2	W-O095277
48	Left Side Main Frame	1	W-A095282
49	Plate Bushing	1	M-S013052
50	Base Plate	1	W-O095284
51	Red Compression Spring	2	M-S031034
52	Nylon Bearing	2	W-S014005
53	Conveyor Belt	4	M-S024002
54	Stacking Wheel Axle	1	M-O008011
55	Stacking Wheel	4	M-S034001
56	Axle Box Housing	4	W-O003090
57	Stacking Finger	1	W-O008013
58	Stacking Wheel Shaft	1	W-O003093
59	Stacking Wheel Weights	2	W-O095268
60	Terminal Block	1	M-S033024
61	Conveyor Shaft	1	W-O095135
62	Square Stacking Wheel Shaft	1	W-O008017
63	Stacking Wheel Hook	1	M-S031060
64	Roller Guard Bracket (R. S.)	1	W-O095265
65	Tie Rod	2	W-O095276
66	Right Side Cover	1	M-O095901
67	Compression Spring	1	M-S031050
68	Main Drive Roller	1	WRA095034
69	Folding Rollers	3	WRA003015
70	Flanged Oilite	1	M-S013010
71	R. S. Main Frame	1	W-A095323
72	7 T.P.I. Perf Wheel	1	W-A03085B
73	Accessory Shaft	1	M-A003018
74	Roller Pinch Guard	1	W-O095279
75	Short Drive Shaft	1	W-O095267
75A	18T "DD" Gear	3	M-O095306
76	Feed Drive Shaft	1	W-O095287
77	150T Timing Belt	1	M-S025026
78	Feed Table Stiffener	1	WRA095104
79	Left Side Roller Bracket	1	W-O095280
79A	Right Side Roller Bracket	1	W-O095265
80	Foot w/ Stud	4	M-S63751408
81	8-32 Keps Nut	4	M-S007006
82	½ X 5/8 X 1 Idler Bushing	1	M-S013053

<u>Item #</u>	<u>Description</u>	<u>Qty.</u>	<u>Part number</u>
83	130T Timing Belt	1	M-S025024
84	14T 3/8I.D. Gear	1	M-O095903
85	Flanged oilite	4	M-S013050
86	18T DD Gear	3	M-O095306
87	Feed Roll Shaft	1	W-O095264
88	Aux. Feed Roll. Shaft	1	W-O095263
89	Retaining Ring	6	M-S010010
90	110XL037 Timing Belt	1	M-S025027
91	10-32 Keps Nut	30	M-S007008
92	12T 3/8 I.D. Pulley	2	M-S022015
93	Guide Roller Arbor	2	M-O003079
94	Rubber Guide Roller	2	M-O003080
95	Stripper	1	M-O003132
96	Angular Adjustment Bracket	1	W-O095014
97	Feed Roller Clutch Bearing	2	M-S020009
98	Angular Adjustment Set Screw	1	M-S002009
99	Nylon Tip	1	M-S043046
100	Deflector Plate	1	W-O008012
101	Pulley Guard Spacer	1	W-O095278
102	Pinch Guard	1	W-A095271
103	Optional Slitter	1	WRA03085A
104	Scoring Roller	2	M-O003083
105	Guide Roller Hub	2	M-O003076
106	Scoring Roller Hub	2	M-O003082
107	Paper Stop	2	W-O095012
108	Spring	4	M-O095036
109	Clamp Stud	4	M-O095322
109A	Stop Clamp	4	M-O095321
110	Thumb Screw	4	M-S032036
111	E- Ring	6	M-S010004
112	Guide Finger Assembly	2	W-A095233
113	Guide Finger Collar	2	M-O095221
114	10-32 x 3/16 SHCS	2	M-S003082
115	#10x1/2x3/64 Flat Washer	2	M-S008005
116	Guide Finger	2	W-O095233
117	Conveyor Idler Shaft	1	W-O003064
118	Label	1	M-S015265
119	8-32 x 3/16 Rd Hd Phillips	3	M-S001128
120	¼ x 20 x 2 Carriage Bolt	1	M-S006015
121	Rod Clamp	2	W-O095020
122	Grip Plate	2	W-O095051
123	3.5A Circuit Breaker	1	M-S045194
124	Cord 120 VAC 60 Hz	1	M-S037002
125	See Next Page		
126	¼ x ½ x 1/16 Flat Washer	1	M-S008008
127	3/8 x 1-1/2 x 1/16 Flat Washer	1	M-S008044
128	Feed Table Assembly	1	WRA095101

220V List (These parts will change to the following with a 220V unit)

<u>Item #</u>	<u>Description</u>	<u>Qty.</u>	<u>Part number</u>
15	Variable Speed Control	1	M-O095207
45	Motor, 220V 50Hz	1	M-S021050
71	Right Side Frame	1	W-O095326
123	2.0A Breaker	1	M-S045195
124	Cord 220V 50Hz	1	M-S037286
125	Noise Filter (220V only)	1	M-S045193

Not Illustrated

8-32x3/16 Rd Hd Phillips	M-S001128
#8 ID Internal Lock Washer	M-S008061
5/16x5/8x3/32 Washer	M-S008068
5/32 Allen Wrench	M-S012009
Wire Tie	M-S043018
Cable Tie Mount	M-S029001
3/32 Allen Wrench	M-S012003
1/8 Allen Wrench	M-S012004
Collar Bushing	M-S013051
Feed Bearing Collar	M-O095266
Shaft Bracket	W-O095269
Pinch Guard—Gear Assembly	W-A095271
Pinch Guard Pulley	W-O095270
Retarder Spring	M-S031075

